

Unit 1 - Fluid Properties & Fluid Statistics

Properties of fluids.

1) Density (ρ) Mass Density

* It is defined as the ratio of the mass of a fluid to its volume.

$$\rho = \frac{\text{Mass}}{\text{Volume}} \quad (\text{kg/m}^3)$$

* Density of liquid may be considered as constant, while that of gases changes with the variation of pressure & temperature.

* \rightarrow Density of Water = 1000 kg/m^3 .

2) Specific Weight (γ) Weight Density

* It is defined as the ratio of weight of a fluid to its volume.

$$\gamma = \frac{\text{Weight}}{\text{Volume}}$$

$$= \frac{\text{Mass of fluid} \times \text{Acceleration due to gravity}}{\text{Volume}}$$

$$\gamma = \rho g$$

* Specific Wt (γ) Wt Density of Water $\rho = 1000 \times 9.81 = 9810 \text{ N/m}^3$

3) Specific Volume

* It is defined as the Volume of a fluid occupied by a unit mass of a fluid.

* It is the reciprocal of density

$$\text{Specific Volume} = \frac{\text{Volume of a fluid}}{\text{Mass of a fluid}} \quad (\text{m}^3/\text{kg})$$

* It is commonly applied to gases.

4) Specific Gravity (Relative density)

* It is the ratio of density of a fluid to the density of a standard fluid. It is denoted by the symbol 'S'.

$$* S \text{ (for liquid)} = \frac{\text{Density of liquid}}{\text{Density of water}}$$

$$* S \text{ (for gases)} = \frac{\text{Density of gas}}{\text{Density of air}}$$

1) Calculate the specific weight, density & sp gravity of 1 litre of a fluid which weight γN

Soln:

$$\begin{aligned}\text{Given data: } * \text{ Volume} &= 1 \text{ litre} \\ &= \frac{1}{1000} \text{ m}^3 \\ &= 1 \times 10^{-3} \text{ m}^3\end{aligned}$$

$$* W = \gamma N$$

To find:

1) $W = ?$

2) $\rho = ?$

3) $\gamma' = ?$

1) Specific weight γ'

$$W = \gamma'$$

$$= \frac{\text{Weight}}{\text{Volume}}$$

Volume

$$= \frac{\gamma}{1 \times 10^{-3}}$$

$$= 7000 \text{ N/m}^3$$

2) ρ density:

$$\rho = \frac{\text{mass}}{\text{Volume}}$$

$$\rho = \frac{\text{mass}}{\text{Volume}} \checkmark$$

$$W = \rho g$$

$$\rho = \frac{W}{g}$$
$$= \frac{7000}{9.81}$$

$$\rho = 713.5 \text{ kg/m}^3$$

3) Sp. gravity:-

$$S' = \frac{\text{density of liquid}}{\text{density of water}}$$

$$= \frac{713.5}{1000}$$

$$= 0.7135$$

Surface Tension

* "It is defined as the tensile force acting on the surface of a liquid in contact with a gas."

Control Volume

* The Control Volume is a volume fixed in space (a) moving with constant velocity through which the fluid flows.

Q) Calculate the density, sp. weight & weight of 1 litre of petrol, if specific gravity = 0.7.

Q. No.

Given data :-

$$\begin{aligned}\text{Volume of petrol} &= 1 \text{ l} \\ &= \frac{1}{1000} \text{ m}^3 \\ &= 1 \times 10^{-3} \text{ m}^3\end{aligned}$$

$$\text{sp. gravity 'S'} = 0.7.$$

To find

- 1) density (ρ) = ?
- 2) Specific Weight (w) = ?
- 3)

1) Density

$$\rho = m/v.$$

$$S = \frac{\text{density of liquid}}{\text{density of water}}$$

$$0.7 = \frac{\text{density of petrol}}{1000}$$

$$\begin{aligned}\rho &= 0.7 \times 1000 \\ &= 700 \text{ kg/m}^3.\end{aligned}$$

2) Specific Weight

$$\begin{aligned} W &= \rho g \\ &= 700 \times 9.81 \\ &= 6867 \text{ N/m}^3 \end{aligned}$$

3) Height

$$W = ?$$

$$\text{Specific Weight} = \frac{\text{Weight}}{\text{Volume}}$$

$$\begin{aligned} W &= 6867 \times 1 \times 10^{-3} \\ &= 6.867 \text{ N} \end{aligned}$$

Different types of fluids

- 1) Ideal Fluid
- 2) Real Fluid
- 3) Newtonian Fluid
- 4) Non-Newtonian fluid
- 5) Ideal plastic fluid

Problem on Surface tension

Formulas:

1) Surface tension on liquid droplet

$$* \quad P = \frac{4\sigma}{d}$$

P = pressure force

σ = Surface tension,

d = diameter

2) Surface tension on a Hollow Bubble / Soap bubble

$$* \quad P = \frac{8\sigma}{d}$$

3) Surface tension on a liquid jet

$$* \quad P = \frac{2\sigma}{d}$$

1) The surface tension of water in contact with air at 20°C is 0.072 N/m . The pressure inside a droplet of water is to be 200 N/m^2 greater than the outside pressure. Calculate the diameter of the droplet of water.

Soln:

Given data

$$\sigma = 0.072 \text{ N/m}$$

$$p = 200 \text{ N/m}^2$$

To find

1) diameter = ?

We know that

$$p = \frac{4\sigma}{d}$$

$$200 = \frac{4 \times 0.072}{d}$$

$$\Rightarrow d = \frac{4 \times 0.072}{200}$$

$$= 1.44 \times 10^{-3} \text{ m} = 1.44 \text{ mm.}$$

CAPILLARITY

Capillarity is defined as a phenomenon of rise or fall of a liquid surface in a small tube relative to the adjacent general level of liquid when the tube is held vertically in the liquid. The rise of liquid surface is known as capillary rise, while the fall of the liquid surface is known as capillary depression. It is expressed in terms of 'cm' or 'mm' of liquid. Its value depends upon the specific weight of the liquid, diameter of the tube and surface tension of the liquid.

EXPRESSION FOR CAPILLARY RISE:

Consider a glass tube of small diameter 'd' opened at both ends and is inserted in a liquid; the liquid will rise in the tube above the level of the liquid outside the tube.

Let 'h' be the height of the liquid in the tube. Under a state of equilibrium, the weight of the liquid of height 'h' is balanced by the force at the surface of the liquid in the tube. But, the force at the surface of the liquid in the tube is due to surface tension.

Let σ = surface tension of liquid

Θ = Angle of contact between the liquid and glass tube

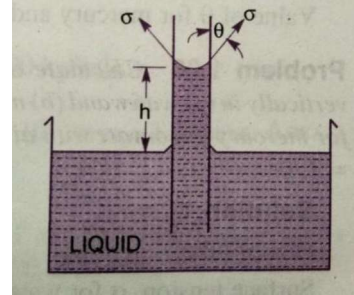

The weight of the liquid of height 'h' in the tube

$$= (\text{area of the tube} \times h) \times \rho \times g = \frac{\pi d^2}{4} \times h \times \rho \times g$$

Where ' ρ ' is the density of the liquid.

The vertical component of the surface tensile force = $(\sigma \times \text{circumference}) \times \cos\Theta = \sigma \times \pi d \times \cos\Theta$

For equilibrium, $\frac{\pi}{4} d^2 \times h \times \rho \times g = \sigma \pi d \cos\Theta$,
$$h = \frac{\sigma \pi d \cos \Theta}{\frac{\pi d^2}{4} \rho \times g} = \frac{4\sigma \cos \Theta}{\rho \times g d}$$

The value of Θ is equal to '0' between water and clean glass tube, then $\cos\Theta = 1$,
$$h = \frac{4\sigma}{\rho \times g \times d}$$

EXPRESSION FOR CAPILLARY FALL:

If the glass tube is dipped in mercury, the Level of mercury in the tube will be lower than the general level of the outside liquid.

Let, h = height of the depression in the tube. Then, in equilibrium, two forces are acting on the mercury inside the tube. First one is due to the surface tension acting in the downward direction = $\sigma \times \pi d \times \cos \theta$

The second force is due to hydrostatic force acting upward and is equal to intensity of pressure at a depth 'h' \times area = $p \times \frac{\pi d^2}{4} = \rho g h \frac{\pi d^2}{4}$ ($p = \rho g h$),

$$\sigma \pi d \cos\theta = \rho g h \frac{\pi d^2}{4}$$

(The value of θ for glass and mercury 128°)

$$h = \frac{\sigma \pi d \cos \theta}{\rho g h \frac{\pi d^2}{4}}$$

$$h = \frac{\sigma \cos \theta}{\rho g d}$$

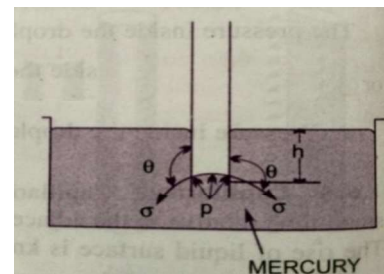

VAPOUR PRESSURE AND CAVITATION

A change from the liquid state to the gaseous state is known as Vaporizations. The vaporization (which depends upon the prevailing pressure and temperature condition) occurs because of continuous escaping of the molecules through the free liquid surface.

Consider a liquid at a temp. of 20°C and pressure is atmospheric is confined in a closed vessel. This liquid will vaporize at 100°C, the molecules escape from the free surface of the liquid and get accumulated in the space between the free liquid surface and top of the vessel. These accumulated vapours exert a pressure on the liquid surface. This pressure is known as vapour pressure of the liquid or pressure at which the liquid is converted in to vapours.

Consider the same liquid at 20 ° c at atmospheric pressure in the closed vessel and the pressure above the liquid surface is reduced by some means; the boiling temperature will also reduce. If the pressure is reduced to such an extent that it becomes equal to or less than the vapour pressure, the boiling of the liquid will start, though the temperature of the liquid is 20°C. Thus, the liquid may boil at the ordinary temperature, if the pressure above the liquid surface is reduced so as to be equal or less than the vapour pressure of the liquid at that temperature.

Now, consider a flowing system, if the pressure at any point in this flowing liquid becomes equal to or less than the vapour pressure, the vapourisation of the liquid starts. The bubbles of these vapours are carried by the flowing liquid in to the region of high pressure where they collapse, giving rise to impact pressure. The pressure developed by the collapsing bubbles is so high that the material from the adjoining boundaries gets eroded and cavities are formed on them. This phenomenon is known as **CAVITATION**.

Hence the cavitations is the phenomenon of formation of vapour bubbles of a flowing liquid in a region where the pressure of the liquid falls below the vapour pressure and sudden collapsing of these vapour bubbles in a region of high pressure,. When the vapour bubbles collapse, a very high pressure is created. The metallic surface, above which the liquid is flowing, is subjected to these high pressures, which cause pitting actions on the surface. Thus cavities are formed on the metallic surface and hence the name is **cavitation**.

ABSOLUTE, GAUGE, ATMOSPHERIC and VACCUM PRESSURES

The pressure on a fluid is measured in two different systems. In one system, it is measured above the absolute zero or complete vacuum and it is called the Absolute pressure and in other system, pressure is measured above the atmospheric pressure and is called Gauge pressure.

1. ABSOLUTE PRESSURE: It is defined as the pressure which is measured with reference to absolute vacuum pressure

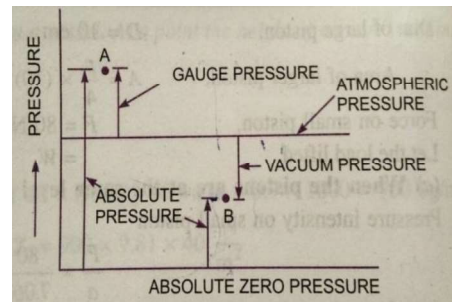

2. GAUGE PRESSURE: It is defined as the pressure, which is measured with the help of a pressure measuring instrument, in which the atmospheric pressure is taken as datum. The atmospheric on the scale is marked as zero.

3. VACUUM PRESSURE: It is defined as the pressure below the atmospheric pressure

i) Absolute pressure = Atmospheric pressure + gauge pressure

$$p_{ab} = p_{atm} + p_{guag}$$

ii) Vacuum pressure = Atmospheric pressure - Absolute pressure

The atmospheric pressure at sea level at 15°C is 10.13 N/cm² or 101.3 kN/m² in S I Units and 1.033 Kg f/cm² in M K S System.

The atmospheric pressure head is 760 mm of mercury or 10.33 m of water.

MEASUREMENT OF PRESSURE

The pressure of a fluid is measured by the following devices.

1. Manometers 2. Mechanical gauges.

1. Manometers: Manometers are defined as the devices used for measuring the pressure at a point in a fluid by balancing the column of fluid by the same or another column of fluid. They are classified as:

a) Simple Manometers b) Differential Manometers.

2. Mechanical Gauges: are defined as the devices used for measuring the pressure by balancing the fluid column by the spring or dead weight. The commonly used Mechanical pressure gauges are:

a) Diaphragm pressure gauge

b) Bourdon tube pressure gauge

c) Dead – Weight pressure gauge

d) Bellows pressure gauge.

Simple Manometers: A simple manometer consists of a glass tube having one of its ends connected to a point where pressure is to be measured and the other end remains open to the atmosphere. The common types of simple manometers are:

1. Piezo meter.
2. U-tube manometer.
3. Single column manometer.

1. Piezometer: It is a simplest form of manometer used for measuring gauge pressure. One end of this manometer is connected to the point where pressure is to be measured and other end is open to the atmosphere. The rise of liquid in the Piezometer gives pressure head at that point A.

The height of liquid say water is 'h' in piezometer tube, then

$$\text{Pressure at A} = \rho g h \frac{N}{m^2}$$

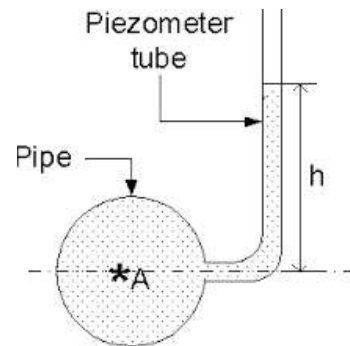

2. U- tube Manometer:

It consists of a glass tube bent in u-shape, one end of which is connected to a point at which pressure is to be measured and other end remains open to the atmosphere. The tube generally contains mercury or any other liquid whose specific gravity is greater than the specific gravity of the liquid whose pressure is to be measured.

a) For Gauge Pressure: Let B is the point at which pressure is to be measured, whose value is p. The datum line A – A

Let h_1 = height of light liquid above datum line

h_2 = height of heavy liquid above datum line

S_1 = sp. gravity of light liquid
 ρ_1 = density of light liquid = 1000 S_1
 S_2 = sp. gravity of heavy liquid
 ρ_2 = density of heavy liquid = 1000 S_2

As the pressure is the same for the horizontal surface. Hence the pressure above the horizontal datum line A – A in the left column and the right column of U – tube manometer should be same.

Pressure above A—A in the left column = $p + \rho_1 gh_1$

Pressure above A – A in the right column = $\rho_2 gh_2$

Hence equating the two pressures $p + \rho_1 gh_1 = \rho_2 gh_2$

$$p = \rho_2 gh_2 - \rho_1 gh_1$$

(b) For Vacuum Pressure:

For measuring vacuum pressure, the level of heavy fluid in the manometer will be as shown in fig.

Pressure above A A in the left column = $\rho_2g h_2 + \rho_1g h_1 + P$

Pressure head in the right column above A A = 0

$$\rho_2g h_2 + \rho_1g h_1 + P = 0$$

$$p = - (\rho_2g h_2 + \rho_1g h_1)$$

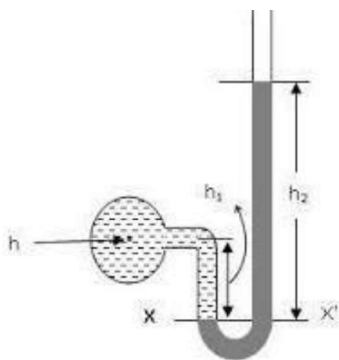

(a) For Gauge Pressure

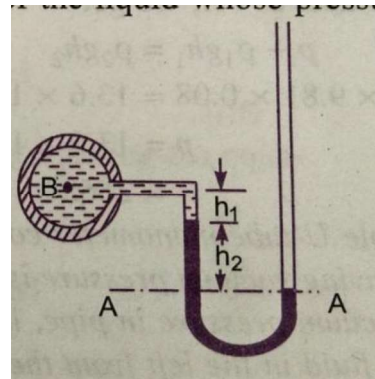

(b) For Vacuum Pressure

SINGLE COLUMN MANOMETER:

Single column manometer is a modified form of a U- tube manometer in which a reservoir, having a large cross sectional area (about. 100 times) as compared to the area of tube is connected to one of the limbs (say left limb) of the manometer. Due to large cross sectional area of the reservoir for any variation in pressure, the change in the liquid level in the reservoir will be very small which may be neglected and hence the pressure is given by the height of the liquid in the other limb. The other limb may be vertical or inclined. Thus, there are two types of single column manometer

1. Vertical single column manometer.
2. Inclined single column manometer.

VERTICAL SINGLE COLUMN MANOMETER:

Let X – X be the datum line in the reservoir and in the right limb of the manometer, when it is connected to the pipe, when the Manometer is connected to the pipe, due to high pressure at A The heavy liquid in the reservoir will be pushed downwards and will rise in the right limb.

Let, Δh = fall of heavy liquid in the reservoir

h_2 = rise of heavy liquid in the right limb

h_1 = height of the centre of the pipe above X – X

p_A = Pressure at A, which is to be measured.

A = Cross- sectional area of the reservoir

a = cross sectional area of the right limb

S_1 = Specific Gravity of liquid in pipe

S_2 = sp. Gravity of heavy liquid in the reservoir and right limb

ρ_1 = density of liquid in pipe

ρ_2 = density of liquid in reservoir

Fall of heavy liquid reservoir will cause a rise of heavy liquid level in the right limb

$$A \times \Delta h = a \times h_2$$

$$\Delta h = \frac{a \times h_2}{A} \quad \text{----- (1)}$$

Now consider the datum line Y – Y

The pressure in the right limb above Y – Y

$$= \rho_2 \times g \times (\Delta h + h_2)$$

Pressure in the left limb above Y – Y

$$= \rho_1 \times g \times (\Delta h + h_1) + P_A$$

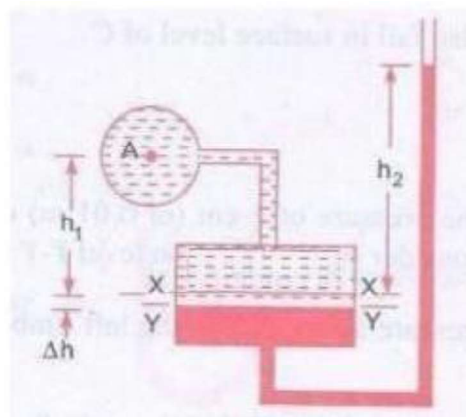

Equating the pressures, we have

$$\rho_2 g \times (\Delta h + h_2) = \rho_1 \times g \times (\Delta h + h_1) + p_A$$

$$p_A = \rho_2 \times g \times (\Delta h + h_2) - \rho_1 \times g \times (\Delta h + h_1)$$

$$= \Delta h (\rho_2 g - \rho_1 g) + h_2 \rho_2 g - h_1 \rho_1 g$$

But, from eq (1) $\Delta h = \frac{a \times h^2}{A}$

~~$$p_A = \frac{a \times h^2}{A} (\rho_2 g - \rho_1 g) + h_2 \rho_2 g - h_1 \rho_1 g$$~~

As the area A is very large as compared to a, hence the ratio $\frac{a}{A}$ becomes very small and can be neglected Then,

$$p_A = h_2 \rho_2 g - h_1 \rho_1 g \text{----- (2)}$$

INCLINED SINGLE COLUMN MANOMETER:

The manometer is more sensitive. Due to inclination the distance moved by heavy liquid in the right limb will be more.

Let L= length of heavy liquid moved in the right limb

Θ = inclination of right limb with horizontal.

H₂ = vertical rise of heavy liquid in the right limb above X – X

$$= L \sin \Theta$$

From above eq (2), the pressure at A is

$$p_A = h_2 \rho_2 g - h_1 \rho_1 g$$

Substituting the value of h₂

$$p_A = L \sin \Theta \rho_2 g - h_1 \rho_1 g$$

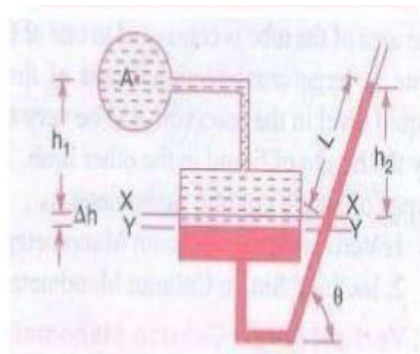

DIFFERENTIAL MANOMETERS:

Differential manometers are the devices used for measuring the difference of pressure between two points in a pipe or in two different pipes. A differential manometer consists of a U-tube, containing heavy liquid, whose two ends are connected to the points, whose difference of pressure is to be measured. The common types of U- tube differential manometers are:

1. U- Tube differential manometer
2. Inverted U- tube differential manometer.

1. U- Tube differential manometer:

a) Let the two points A and B are at different levels and also contains liquids of different sp.gr.

b) These points are connected to the U – Tube differential manometer.

Let the pressure at A and B are p_A and p_B .

Let h = Difference of mercury levels in the u – tube

y = Distance of centre of B from the mercury level in the right limb

x = Distance of centre of A from the mercury level in the left limb

ρ_1 = Density of liquid A

ρ_2 = Density of liquid B

ρ_g = Density of heavy liquid or mercury

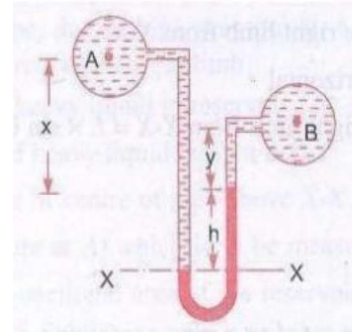

Taking datum line at X – X

Pressure above X – X in the left limb = $\rho_1 g (h + x) + p_A$ (where p_A = Pressure at A)

Pressure above X – X in the right limb = $\rho_g g h + \rho_2 g y + p_B$ (where p_B = Pressure at B)

Equating the above two pressures, we have

$$\rho_1 g (h + x) + p_A = \rho_g g h + \rho_2 g y + p_B$$

$$p_A - p_B = \rho_g g h + \rho_2 g y - \rho_1 g (h + x)$$

$$= h g (\rho_g - \rho_1) + \rho_2 g y - \rho_1 g x$$

\therefore Difference of Pressures at A and B = $h g (\rho_g - \rho_1) + \rho_2 g y - \rho_1 g x$

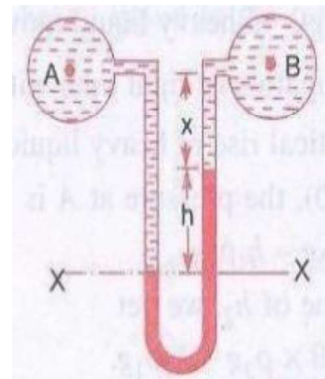

Let the two points A and B are at the same level and contains the same liquid of density ρ_1

Then pressure above X – X in the right limb = $\rho_g g h + \rho_1 g x + p_B$

Pressure above X – X in the left limb = $\rho_1 g (h + x) + p_A$

Equating the two pressures

$$\rho_g g h + \rho_1 g x + p_B = \rho_1 g (h + x) + p_A$$

$$p_A - p_B = \rho_g g h + \rho_1 g x - \rho_1 g (h + x)$$

$$= g h (\rho_g - \rho_1)$$

Difference of pressure at A and B = $g h (\rho_g - \rho_1)$

Inverted U – Tube differential manometer

It consists of an inverted U – tube, containing a light liquid. The two ends of the tube are connected to the points whose difference of pressure is to be measured. It is used for measuring difference of low pressures. Let an inverted U – tube differential manometer connected to the two points A and B. Let pressure at A is more than pressure at B.

Let h_1 = Height of the liquid in the left limb below the datum line X-X

h_2 = Height of the liquid in the right limb.

h = Difference of height of liquid

ρ_1 = Density of liquid A

ρ_2 = Density of liquid B

ρ_s = Density of light liquid

p_A = Pressure at A

p_B = Pressure at B

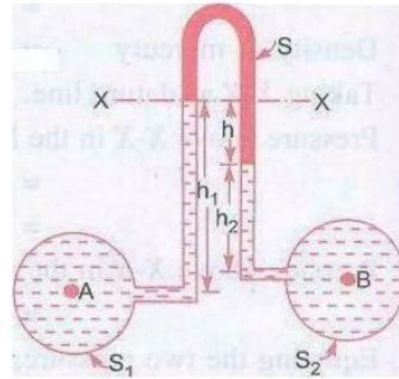

Taking $x - x$ as datum line

The pressure in the left limb below $x - x = p_A - \rho_1 g h_1$

Pressure in the right limb below $x - x = p_B - \rho_2 g h_2 - \rho_s g h$

Equating the above two pressures

$$p_A - \rho_1 g h_1 = p_B - \rho_2 g h_2 - \rho_s g h$$

$$p_A - p_B = \rho_1 g h_1 - \rho_2 g h_2 - \rho_s g h$$

Difference of pressure at A and B = $\rho_1 g h_1 - \rho_2 g h_2 - \rho_s g h$

PROBLEMS

1. Calculate the density, specific weight and weight of one liter of petrol of specific gravity = 0.7

Sol: i) Density of a liquid = $S \times$ Density of water = $S \times 1000 \text{ kg/m}^3$

$$\rho = 0.7 \times 1000$$

$$\rho = 700 \text{ Kg/m}^3$$

ii) Specific weight $w = \rho \times g = 700 \times 9.81 = 6867 \text{ N/m}^3$

iii) Weight (w) Volume = 1 liter = $1 \times 1000 \text{ cm}^3 = \frac{1000 \text{ m}^3}{10^6} = \underline{\underline{0.001 \text{ m}^3}}$

We know that, specific weight $w = \frac{\text{weight of fluid}}{\text{volume of the fluid}}$

Weight of petrol = $w \times$ volume of petrol

$$= w \times 0.001$$

$$= 6867 \times 0.001 = \underline{\underline{6.867 \text{ N}}}$$

2. Two horizontal plates are placed 1.25 cm apart, the space between them being filled with oil of viscosity 14 poises. Calculate shear stress in oil, if the upper plate is moved velocity of 2.5 m/sec.

Sol: Given distance between the plates $dy = 1.25 \text{ cm} = 0.0125 \text{ m}$

$$\text{Viscosity } \mu = 14 \text{ poise} = \frac{14}{10} \text{ N s/m}^2$$

Velocity of upper plate $u = 2.5 \text{ m/sec}$

$$\text{Shear stress } \tau = \mu \frac{du}{dy}$$

Where $du = \text{change of velocity between plates} = u - 0 = u = 2.5 \text{ m/sec}$

$$\tau = \frac{14}{10} \times \frac{2.5}{0.0125}$$

$$\underline{\text{Shear stress } \tau = 280 \text{ N/m}^2}$$

3. The dynamic viscosity of oil used for lubrication between a shaft and sleeve is 6 poise. The shaft dia. is 0.4m and rotates at 190 rpm. Calculate the power lost in the bearing for a sleeve length of 90mm. The thickness foil film is 1.5mm

Sol: Given, Viscosity $\mu = 6 \text{ poise} = \frac{6}{10} \frac{\text{N s}}{\text{m}^2} = 0.6$

Dia. of shaft $D = 0.4 \text{ m}$

Speed of shaft $N = 190 \text{ rpm}$

Sleeve length $L = 90 \text{ mm} = 90 \times 10^{-3} \text{ m}$

Thickness of a film $t = 1.5 \text{ mm} = 1.5 \times 10^{-3} \text{ m}$

Tangential velocity of shaft $= u = \frac{\pi DN}{60} = \frac{\pi \times 0.4 \times 190}{60} = 3.98 \text{ m/sec}$

Using the relation $\tau = \mu \frac{du}{dy}$

Where $du = \text{change of velocity} = u - 0 = u = 3.98 \text{ m/sec}$

$dy = \text{change of distance} = t = 1.5 \times 10^{-3} \text{ m}$

$$\tau = 0.6 \times \frac{3.98}{1.5 \times 10^{-3}} = 1592 \text{ N/m}^2$$

This is the shear stress on the shaft

Shear force on the shaft $F = \text{shear stress} \times \text{area} = 1592 \times \pi DL = 1592 \times \pi \times 0.4 \times 90 \times 10^{-3}$
 $= 180.05 \text{ N}$

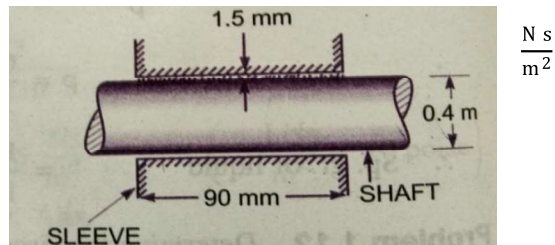

$$\text{Torque on the shaft } T = \text{Force} \times \frac{D}{2} = 180.05 \times \frac{0.4}{2} = 36.01 \text{ Nm}$$

$$\text{Power lost} = \frac{2\pi NT}{60} = 36.01 \times \frac{2\pi \times 190}{60} \times 36.01$$

Power lost = 716.48 W

4. A cylinder 0.12m radius rotates concentrically inside a fixed cylinder of 0.13 m radius. Both cylinders are 0.3m long. Determine the viscosity of liquid which fills the space between the cylinders, if a torque of 0.88 Nm is required to maintain an angular velocity of 2π rad / sec.

Sol : Diameter of inner cylinder = 0.24m

Diameter of outer cylinder = 0.26 m

Length of cylinder $L = 0.3 \text{ m}$

Torque $T = 0.88 \text{ NM}$

$\omega = 2\pi \text{ N}/60 = 2\pi$

$N = \text{speed} = 60 \text{ rpm}$

Let the viscosity = μ

Tangential velocity of cylinder $u = \frac{\pi DN}{60} = \frac{\pi \times 0.24 \times 60}{60} = 0.7536 \text{ m/sec}$

Surface area of cylinder $A = \pi DL = \pi \times 0.24 \times 0.3 = 0.226 \text{ m}^2$

Now using the relation $\tau = \mu \frac{du}{dy}$

Where $du = u - 0 = 0.7536 \text{ m/sec}$

$$dy = \frac{0.26 - 0.24}{2} = 0.02 = 0.01 \text{ m}$$

$$\tau = \mu \times \frac{0.7536}{0.01}$$

Shear force, $F = \text{shear stress} \times \text{area}$

$$= \mu \times 75.36 \times 0.226 = 17.03 \mu$$

Torque $T = F \times D/2 = 17.03 \mu \times \frac{0.24}{2}$

$$0.88 = \mu \times 2.0436$$

$$\mu = \frac{0.88}{2.0436}$$

$$= 0.4306 \text{ Ns/m}^2$$

$$= 0.4306 \times 10 \text{ poise}$$

Viscosity of liquid = 4.306 poise

5. The right limb of a simple U – tube manometer containing mercury is open to the atmosphere, while the left limb is connected to a pipe in which a fluid of sp.gr.0.9 is flowing. The centre of pipe is 12cm below the level of mercury in the right limb. Find the pressure of fluid in the pipe, if the difference of mercury level in the two limbs is 20 cm.

Given, Sp.gr. of liquid $S_1 = 0.9$

Density of fluid $\rho_1 = S_1 \times 1000 = 0.9 \times 1000 = 900 \text{ kg/m}^3$

Sp.gr. of mercury $S_2 = 13.6$

Density of mercury $\rho_2 = 13.6 \times 1000 = 13600 \text{ kg/m}^3$

Difference of mercury level $h_2 = 20 \text{ cm} = 0.2 \text{ m}$

Height of the fluid from A – A $h_1 = 20 - 12 = 8 \text{ cm} = 0.08 \text{ m}$

Let 'P' be the pressure of fluid in pipe

Equating pressure at A – A, we get

$$p + \rho_1 g h_1 = \rho_2 g h_2$$

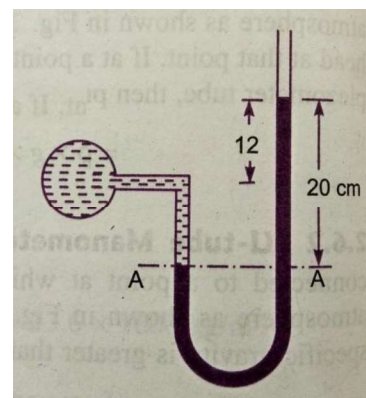

$$p + 900 \times 9.81 \times 0.08 = 13.6 \times 1000 \times 9.81 \times 0.2$$

$$p = 13.6 \times 1000 \times 9.81 \times 0.2 - 900 \times 9.81 \times 0.08$$

$$p = 26683 - 706$$

$$p = 25977 \text{ N/m}^2$$

$$p = 2.597 \text{ N/cm}^2$$

$$\text{Pressure of fluid} = 2.597 \text{ N/cm}^2$$

6. A simple U – tube manometer containing mercury is connected to a pipe in which a fluid of sp.gr. 0.8 And having vacuum pressure is flowing. The other end of the manometer is open to atmosphere. Find the vacuum pressure in pipe, if the difference of mercury level in the two limbs is 40cm. and the height of the fluid in the left tube from the centre of pipe is 15cm below.

Given,

$$\text{Sp.gr of fluid} \quad S_1 = 0.8$$

$$\text{Sp.gr. of mercury } S_2 = 13.6$$

$$\text{Density of the fluid} = S_1 \times 1000 = 0.8 \times 1000 = 800$$

$$\text{Density of mercury} = 13.6 \times 1000$$

$$\text{Difference of mercury level } h_2 = 40\text{cm} = 0.4\text{m}$$

$$\text{Height of the liquid in the left limb} = 15\text{cm} = 0.15\text{m}$$

Let the pressure in the pipe = p

Equating pressures above datum line A-- A

$$\rho_2 g h_2 + \rho_1 g h_1 + P = 0$$

$$P = - [\rho_2 g h_2 + \rho_1 g h_1]$$

$$= - [13.6 \times 1000 \times 9.81 \times 0.4 + 800 \times 9.81 \times 0.15]$$

$$= 53366.4 + 1177.2$$

$$= -54543.6 \text{ N/m}^2$$

$$\text{P} = - 5.454 \text{ N/cm}^2$$

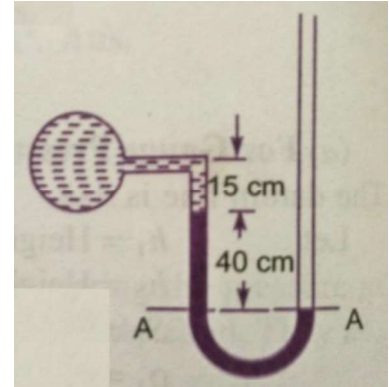

7. What are the gauge pressure and absolute pressure at a point 3m below the surface of a liquid having a density of $1.53 \times 10^3 \text{ kg/m}^3$? If the atmospheric pressure is equivalent to 750mm of mercury. The specific gravity of mercury is 13.6 and density of water 1000 kg/m^3

Given:

$$\text{Depth of the liquid, } z_1 = 3\text{m}$$

$$\text{Density of liquid} \quad \rho_1 = 1.53 \times 10^3 \text{ kg/ m}^3$$

$$\text{Atmospheric pressure head } z_0 = 750 \text{ mm of mercury} = \frac{750}{1000} = 0.75\text{m of Hg}$$

$$\text{Atmospheric pressure } p_{\text{atm}} = \rho_0 \times g \times z_0$$

$$\text{Where } \rho_0 = \text{density of Hg} = \text{sp.gr. of mercury} \times \text{density of water}$$

$$= 13.6 \times 1000 \text{ kg/ m}^3$$

And $z_0 =$ pressure head in terms of mercury = 0.75m of Hg

$$P_{\text{atm}} = (13.6 \times 1000) \times 9.81 \times 0.75 \text{ N/m}^2$$

$$= 100062 \text{ N/ m}^2$$

Pressure at a point, which is at a depth of 3m from the free surface of the liquid is

$$P = \rho_1 \times g \times z_1 = 1.53 \times 10^3 \times 9.81 \times 3$$

$$\text{Gauge pressure } P = 45028 \text{ N/ m}^2$$

$$\begin{aligned} \text{Absolute Pressure} &= \text{Gauge pressure} + \text{Atmospheric pressure} \\ &= 45028 + 100062 \end{aligned}$$

$$\text{Absolute Pressure} = 145090 \text{ N/m}^2$$

8. A single column manometer is connected to the pipe containing liquid of sp.gr.0.9. Find the pressure in the pipe if the area of the reservoir is 100 times the area of the tube of manometer. sp.gr. of mercury is 13.6. Height of the liquid from the centre of pipe is 20cm and difference in level of mercury is 40cm.

Given,

Sp.gr. of liquid in pipe	$S_1 = 0.9$
Density	$\rho_1 = 900 \text{ kg/m}^3$
Sp.gr. of heavy liquid	$S_2 = 13.6$
Density	$\rho_2 = 13600$
$\frac{\text{Area of reservoir}}{\text{Area of right limb}}$	$= \frac{A}{a} = 100$
Height of the liquid	$h_1 = 20\text{cm} = 0.2\text{m}$
Rise of mercury in the right limb	$h_2 = 40\text{cm} = 0.4\text{m}$

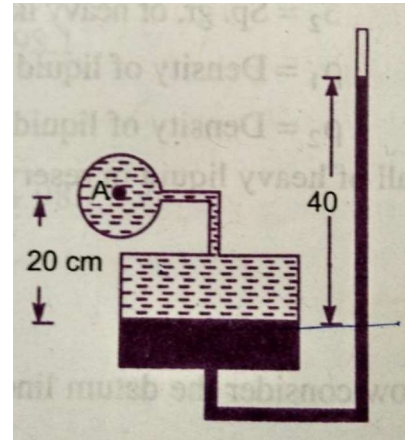

Pressure in pipe A

$$\begin{aligned} p_A &= \frac{A}{a} \times h [\rho_2 g - \rho_1 g] + h_1 \rho_1 g - h_2 \rho_2 g \\ &= \frac{1}{100} \times 0.4 [13600 \times 9.81 - 900 \times 9.81] + 0.4 \times 13600 \times 9.81 - 0.2 \times 900 \times 9.81 \\ &= \frac{0.4}{100} [133416 - 8829] + 53366.4 - 1765.8 \\ &= 533.664 + 53366.4 - 1765.8 \\ &= 52134 \text{ N/m}^2 \end{aligned}$$

Pressure in pipe A = 5.21 N/cm²

9. A pipe contains an oil of sp.gr.0.9. A differential manometer is connected at the two points A and B shows a difference in mercury level at 15cm. find the difference of pressure at the two points.

Given: Sp.gr. of oil $S_1 = 0.9$; density $\rho_1 = 0.9 \times 1000 = 900 \text{ kg/m}^3$

Difference of level in the mercury $h = 15\text{cm} = 0.15 \text{ m}$

Sp.gr. of mercury = 13.6, Density = $13.6 \times 1000 = 13600 \text{ kg/m}^3$

The difference of pressure $p_A - p_B = g \times h \times (\rho_g - \rho_1)$

$$= 9.81 \times 0.15 (13600 - 900)$$

$$\underline{p_A - p_B = 18688 \text{ N/m}^2}$$

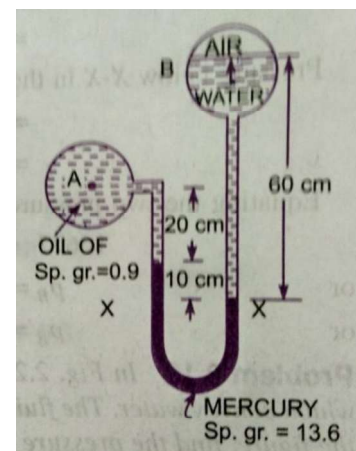

10. A differential manometer is connected at two points A and B. At B air pressure is 9.81 N/cm^2 . Find absolute pressure at A.

Density of air = $0.9 \times 1000 = 900 \text{ kg/m}^3$

Density of mercury = $13.6 \times 10^3 \text{ kg/m}^3$

Let pressure at A is p_A

Taking datum as X – X

Pressure above X – X in the right limb

$$= 1000 \times 9.81 \times 0.6 + p_B = 5886 + 98100 = 103986$$

Pressure above X – X in the left limb

$$= 13.6 \times 10^3 \times 9.81 \times 0.1 + 9000 \times 9.81 \times 0.2 + p_A$$

$$= 13341.6 + 1765.8 + p_A$$

Equating the two pressures heads

$$103986 = 13341.6 + 1765.8 + p_A$$

$$= 15107.4 + p_A$$

$$p_A = 103986 - 15107.4$$

$$= 88878.6 \text{ N/m}^2$$

$$\underline{p_A = 8.887 \text{ N/cm}^2}$$

11. Water is flowing through two different pipes to which an inverted differential manometer having an oil of sp.gr. 0.8 is connected. The pressure head in the pipe A is 2m of water. Find the pressure in the pipe B for the manometer readings shown in fig.

Given: Pressure head at A = $\frac{p_A}{\rho g} = 2\text{m of water}$

$$p_A = \rho \times g \times 2 = 1000 \times 9.81 \times 2 = 19620 \text{ N/m}^2$$

Pressure below X – X in the left limb

$$= p_A - \rho_1 g h_1$$

$$= 19620 - 1000 \times 9.81 \times 0.3 = 16677 \text{ N/m}^2$$

Pressure below X – X in the right limb

$$= p_B - 1000 \times 9.81 \times 0.1 - 800 \times 9.81 \times 0.12$$

$$= p_B - 981 - 941.76 = p_B - 1922.76$$

Equating the two pressures, we get,

$$16677 = p_B - 1922.76$$

$$p_B = 16677 + 1922.76$$

$$\underline{p_B = 18599.76 \text{ N/m}^2}$$

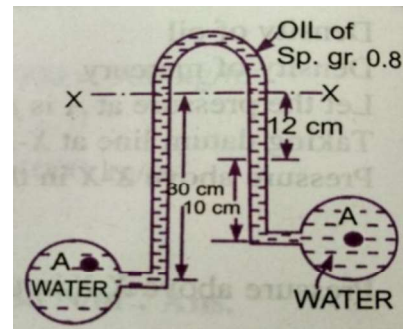

12. A differential manometer is connected at two points A and B of two pipes. The pipe A contains liquid of sp.gr. = 1.5 while pipe B contains liquid of sp.gr. = 0.9. The pressures at A and B are 1 kgf/cm² and 1.80 Kg f/cm² respectively. Find the difference in mercury level in the differential manometer.

Sp.gr. of liquid at A $S_1 = 1.5$

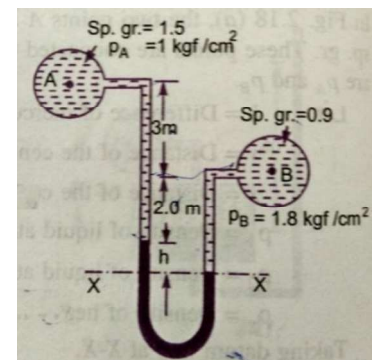

Sp.gr. of liquid at B $S_2 = 0.9$

Pressure at A $p_A = 1 \text{ kgf/cm}^2 = 1 \times 10^4 \times \text{kg/m}^2 = 1 \times 10^4 \times 9.81 \text{ N/m}^2$

Pressure at B $p_B = 1.8 \text{ kgf/cm}^2 = 1.8 \times 10^4 \times 9.81 \text{ N/m}^2$ [1kgf = 9.81 N]

Density of mercury = $13.6 \times 1000 \text{ kg/m}^3$

Taking X – X as datum line

Pressure above X – X in left limb

$$= 13.6 \times 1000 \times 9.81 \times h + 1500 \times 9.81(2+3) + (9.81 \times 10^4)$$

Pressure above X – X in the right limb = $900 \times 9.81(h + 2) + 1.8 \times 9.81 \times 10^4$

Equating the two pressures, we get

$$13.6 \times 1000 \times 9.81h + 1500 \times 9.81 \times 5 + 9.81 \times 10^4 = 900 \times 9.81(h + 2) + 1.8 \times 9.81 \times 10^4$$

Dividing both sides by 1000×9.81

$$13.6h + 7.5 + 10 = 0.9(h+2) + 18$$

$$(13.6 - 0.9)h = 1.8 + 18 - 17.5 = 19.8 - 17.5 = 2.3$$

$$h = \frac{2.3}{12.7} = 0.181\text{m}$$

$$\mathbf{h = 18.1 \text{ cm}}$$

UNIT-2

FLUID KINEMATICS

Kinematics is defined as a branch of science which deals with motion of particles without considering the forces causing the motion. The velocity at any point in a flow field at any time is studied in this. Once the velocity is known, then the pressure distribution and hence the forces acting on the fluid can be determined.

Stream line: A stream line is an imaginary line drawn in a flow field such that the tangent drawn at any point on this line represents the direction of velocity vector. From the definition it is clear that there can be no flow across stream line. Considering a particle moving along a stream line for a very short distance 'ds' having its components dx, dy and dz, along three mutually perpendicular co-ordinate axes. Let the components of velocity vector V_s along x, y and z directions be u, v and w respectively. The time taken by the fluid particle to move a distance 'ds' along the stream line with a velocity V_s is:

$$= \frac{ds}{V_s} \quad \text{Which is same as } t = \frac{dx}{u} = \frac{dy}{v} = \frac{ds}{w}$$

Hence the differential equation of the stream line may be written as:

$$\frac{dx}{u} = \frac{dy}{v} = \frac{ds}{w}$$

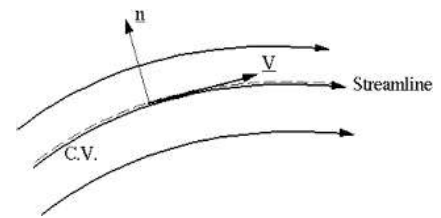

Path line: A path line is locus of a fluid particle as it moves along. In other words a path line is a curve traced by a single fluid particle during its motion. A stream line at time t_1 indicating the velocity vectors for particles A and B. At times t_2 and t_3 the particle A occupies the successive positions. The line containing these various positions of A represents its **Path line**

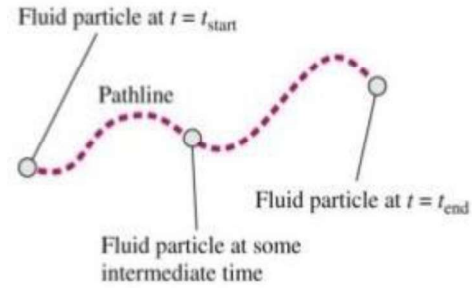

Streak line: When a dye is injected in a liquid or smoke in a gas, so as to trace the subsequent motion of fluid particles passing a fixed point, the path followed by dye or smoke is called the **streak line**. Thus the streak line connects all particles passing through a given point.

In steady flow, the stream line remains fixed with respect to co-ordinate axes. Stream lines in steady flow also represent the path lines and streak lines. In unsteady flow, a fluid particle will not, in general, remain on the same stream line (except for unsteady uniform flow). Hence the stream lines and path lines do not coincide in unsteady non-uniform flow.

Instantaneous stream line: in a fluid motion which is independent of time, the position of stream line is fixed in space and a fluid particle following a stream line will continue to do so. In case of time dependent flow, a fluid particle follows a stream line for only a short interval of time, before changing over to another stream line. The stream lines in such cases are not fixed in space, but change with time. The position of a stream line at a given instant of time is known as **Instantaneous stream line**. For different instants of time, we shall have different Instantaneous stream lines in the same space. The Stream line, Path line and the streak line are one and the same, if the flow is steady.

Stream tube: If stream lines are drawn through a closed curve, they form a boundary surface across which fluid cannot penetrate. Such a surface bounded by stream lines is known as **Stream tube**.

From the definition of stream tube, it is evident that no fluid can cross the bounding surface of the stream tube. This implies that the quantity of fluid entering the stream tube at one end must be the same as the quantity leaving at the other end. The Stream tube is assumed to be a small cross-sectional area, so that the velocity over it could be considered uniform.

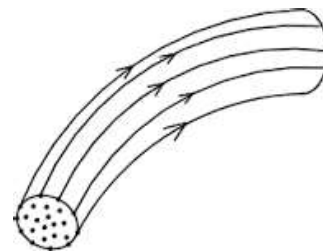

CLASSIFICATION OF FLOWS

The fluid flow is classified as:

- i) Steady and unsteady flows.
- ii) Uniform and Non-uniform flows.
- iii) Laminar and Turbulent flows.
- iv) Compressible and incompressible flows.
- v) Rotational and Ir-rotational flows.
- vi) One, two and three dimensional flows.

i) Steady and Un-steady flows: Steady flow is defined as the flow in which the fluid characteristics like velocity, pressure, density etc. at a point do not change with time.

Thus for a steady flow, we have

$$\frac{\partial V}{\partial t_{x,y,z}} = 0, \quad \frac{\partial p}{\partial t_{x,y,z}} = 0, \quad \frac{\partial \rho}{\partial t_{x,y,z}} = 0$$

Un-Steady flow is the flow in which the velocity, pressure, density at a point changes with respect to time. Thus for un-steady flow, we have

$$\frac{\partial V}{\partial t_{x,y,z}} \neq 0, \quad \frac{\partial p}{\partial t_{x,y,z}} \neq 0, \quad \frac{\partial \rho}{\partial t_{x,y,z}} \neq 0$$

ii) Uniform and Non-uniform flows:

Uniform flow is defined as the flow in which the velocity at any given time does not change with respect to space. (i.e. the length of direction of flow)

$$\text{For uniform flow } \frac{\partial V}{\partial s_{t=\text{const}}} = 0$$

Where ∂V = Change of velocity

∂s = Length of flow in the direction of – S

Non-uniform is the flow in which the velocity at any given time changes with respect to space.

$$\text{For Non-uniform flow } \frac{\partial V}{\partial s_{t=\text{const}}} \neq 0$$

iii) Laminar and turbulent flow:

Laminar flow is defined as the flow in which the fluid particles move along well-defined paths or stream line and all the stream lines are straight and parallel. Thus the particles move in laminas or layers gliding smoothly over the adjacent layer. This type of flow is also called streamline flow or viscous flow.

Turbulent flow is the flow in which the fluid particles move in a zigzag way. Due to the movement of fluid particles in a zigzag way, the eddies formation takes place, which are responsible for high energy loss. For a pipe flow, the type of flow is determined by a non-Dimensional number $\frac{VD}{\nu}$ called the Reynolds number.

Where D = Diameter of pipe.

V = Mean velocity of flow in pipe.

ν = Kinematic viscosity of fluid.

If the Reynolds number is less than 2000, the flow is called Laminar flow.

If the Reynolds number is more than 4000, it is called Turbulent flow.

If the Reynolds number is between 2000 and 4000 the flow may be Laminar or Turbulent flow.

iv) Compressible and Incompressible flows:

Compressible flow is the flow in which the density of fluid changes from point to point or in other words the density is not constant for the fluid.

For compressible flow $\rho \neq \text{Constant}$.

Incompressible flow is the flow in which the density is constant for the fluid flow. Liquids are generally incompressible, while the gases are compressible.

For incompressible flow $\rho = \text{Constant}$.

v) Rotational and Irrotational flows:

Rotational flow is a type of flow in which the fluid particles while flowing along stream lines also rotate about their own axis. And if the fluid particles, while flowing along stream lines, do not rotate about their own axis, the flow is called Ir-rotational flow.

vi) One, Two and Three – dimensional flows:

One dimensional flow is a type of flow in which flow parameter such as velocity is a function of time and one space co-ordinate only, say 'x'. For a steady one- dimensional flow, the velocity is a function of one space co-ordinate only. The variation of velocities in other two mutually perpendicular directions is assumed negligible.

Hence for one dimensional flow $\mathbf{u} = f(x)$, $\mathbf{v} = \mathbf{0}$ and $\mathbf{w} = \mathbf{0}$

Where u, v and w are velocity components in x, y and z directions respectively.

Two – dimensional flow is the type of flow in which the velocity is a function of time and two space co-ordinates, say x and y. For a steady two-dimensional flow the velocity is a function of two space co-ordinates only. The variation of velocity in the third direction is negligible.

Thus for two dimensional flow $\mathbf{u} = f_1(x, y)$, $\mathbf{v} = f_2(x, y)$ and $\mathbf{w} = \mathbf{0}$.

Three – dimensional flow is the type of flow in which the velocity is a function of time and three mutually perpendicular directions. But for a steady three-dimensional flow, the fluid parameters are functions of three space co-ordinates (x, y, and z) only.

Thus for **three- dimensional flow** $\mathbf{u} = f_1(x, y, z)$, $\mathbf{v} = f_2(x, y, z)$, $\mathbf{z} = f_3(x, y, z)$.

Rate of flow or Discharge (Q)

It is defined as the quantity of a fluid flowing per second through a section of pipe or channel. For an incompressible fluid (or liquid) the rate of flow or discharge is expressed as the volume of the liquid flowing cross the section per second. or compressible fluids, the rate of flow is usually expressed as the weight of fluid flowing across the section.

Thus i) For liquids the unit of Q is m^3/sec or Litres/sec. ii)

For gases the unit of Q is Kg f/sec or Newton/sec.

$$\text{The discharge } Q = A \times V$$

Where, A = Area of cross-section of pipe.

V = Average velocity of fluid across the section.

CONTINUITY EQUATION

The equation based on the principle of conservation of mass is called Continuity equation. Thus for a fluid flowing through the pipe at all cross- sections, the quantity of fluid per second is constant. Consider two cross- sections of a pipe.

Let V_1 = Average velocity at cross- section 1-1

ρ_1 = Density of fluid at section 1-1

A_1 = Area of pipe at section 1-1

And V_2, ρ_2, A_2 are the corresponding values at section 2—2

Then the rate flow at section 1-1 = $\rho_1 A_1 V_1$

Rate of flow at section 2—2 = $\rho_2 A_2 V_2$

According to law of conservation of mass

Rate of flow at section 1---1 = Rate of flow at section 2---2

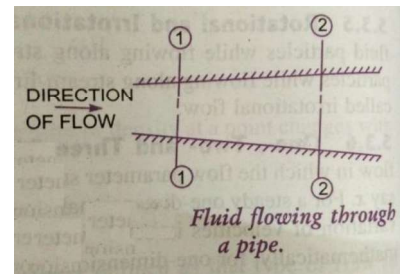

$$\rho_1 A_1 V_1 = \rho_2 A_2 V_2$$

This equation is applicable to the compressible as well as incompressible fluids and is called “**Continuity equation**”. If the fluid is incompressible, then $\rho_1 = \rho_2$ and the continuity equation reduces to

$$A_1 V_1 = A_2 V_2$$

CONTINUITY EQUATION IN THREE DIMENSIONAL FLOW

Consider a fluid element of lengths dx , dy and dz in the direction of x , y and z . Let u , v and w are the inlet velocity components in x , y and z directions respectively.

Mass of fluid entering the face ABCD per second

$$\begin{aligned} \text{ABCD} &= \rho \times \text{velocity in } x\text{-direction} \times \text{Area of} \\ &= \rho \times u \times (dy \times dz) \end{aligned}$$

Then the mass of fluid leaving the face EFGH per second

$$= \rho \times u \times (dy \times dz) + \frac{\partial}{\partial x} \rho u \, dy \, dz \, dx$$

Gain of mass in x - direction

= Mass through ABCD – Mass through EFGH per second.

$$= \rho u \, dy \, dz - \rho u \, dy \, dz - \frac{\partial}{\partial x} \rho u \, dy \, dz \, dx$$

$$= - \frac{\partial}{\partial x} \rho u \, dy \, dz \, dx$$

$$= - \frac{\partial}{\partial x} \rho u \, dx \, dy \, dz \quad \text{_____ (1)}$$

Similarly the net gain of mass in y - direction.

$$= - \frac{\partial}{\partial y} \rho v \, dx \, dy \, dz \quad \text{_____ (2)}$$

$$\text{In } z\text{- direction} = - \frac{\partial}{\partial z} (\rho w) \, dx \, dy \, dz \quad \text{_____ (3)}$$

$$\text{Net gain of mass} = - \frac{\partial}{\partial x} \rho u + \frac{\partial}{\partial y} \rho v + \frac{\partial}{\partial z} \rho w \, dx \, dy \, dz \quad \text{_____ (4)}$$

Since mass is neither created nor destroyed in the fluid element, the net increase of mass per unit time in the fluid element must be equal to the rate of increase of mass of fluid in the element. But the mass of fluid in the element is $\rho \, dx \, dy \, dz$ and its rate of increase with time is $\frac{\partial}{\partial t} (\rho \, dx \, dy \, dz)$ or $\frac{\partial \rho}{\partial t} \, dx \, dy \, dz$. (5)

Equating the two expressions (4) & (5)

$$- \left(\frac{\partial}{\partial x} \rho u + \frac{\partial}{\partial y} \rho v + \frac{\partial}{\partial z} \rho w \right) dx \, dy \, dz = \frac{\partial \rho}{\partial t} \, dx \, dy \, dz.$$

$$\frac{\partial \rho}{\partial t} + \frac{\partial}{\partial x} \rho u + \frac{\partial}{\partial y} \rho v + \frac{\partial}{\partial z} \rho w = 0 \quad \text{_____ (6)}$$

This equation is applicable to

- i) Steady and unsteady flow
- ii) Uniform and non- uniform flow, and
- iii) Compressible and incompressible flow.

For steady flow $\frac{\partial \rho}{\partial t} = 0$ and hence equation (6) becomes

$$\frac{\partial}{\partial x} \rho u + \frac{\partial}{\partial y} \rho v + \frac{\partial}{\partial z} \rho w = 0 \quad \text{_____ (7)}$$

If the fluid is incompressible, then ρ is constant and the above equation becomes

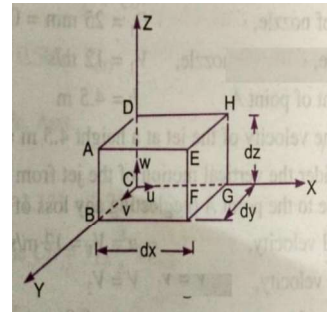

$$\frac{\partial u}{\partial x} + \frac{\partial v}{\partial y} + \frac{\partial w}{\partial z} = 0 \quad \text{--- (8)}$$

This is the continuity equation in three - dimensional flow.

FLUID DYNAMICS

A fluid in motion is subjected to several forces, which results in the variation of the acceleration and the energies involved in the flow of the fluid. The study of the forces and energies that are involved in the fluid flow is known as Dynamics of fluid flow.

The various forces acting on a fluid mass may be classified as:

1. Body or volume forces
2. Surface forces
3. Line forces.

Body forces: The body forces are the forces which are proportional to the volume of the body.

Examples: Weight, Centrifugal force, magnetic force, Electromotive force etc.

Surface forces: The surface forces are the forces which are proportional to the surface area which may include pressure force, shear or tangential force, force of compressibility and force due to turbulence etc.

Line forces: The line forces are the forces which are proportional to the length.

Example is surface tension.

The dynamics of fluid flow is governed by Newton's second law of motion which states that the resultant force on any fluid element must be equal to the product of the mass and acceleration of the element and the acceleration vector has the direction of the resultant vector. The fluid is assumed to be incompressible and non- viscous.

$$\sum F = M. a$$

Where $\sum F$ represents the resultant external force acting on the fluid element of mass **M** and **a** is total acceleration. Both the acceleration and the resultant external force must be along same line of action. The force and acceleration vectors can be resolved along the three reference directions x, y and z and the corresponding equations may be expressed as ;

$$\sum F_x = M. a_x$$

$$\sum F_y = M. a_y$$

$$\sum F_z = M. a_z$$

Where $\sum F_x$, $\sum F_y$ and $\sum F_z$ are the components of the resultant force in the x, y and z directions respectively, and a_x , a_y and a_z are the components of the total acceleration in x, y and z directions respectively.

FORCES ACTING ON FLUID IN MOTION:

The various forces that influence the motion of fluid are due to gravity, pressure, viscosity, turbulence and compressibility.

The gravity force F_g is due to the weight of the fluid and is equal to Mg . The gravity force per unit volume is equal to “ ρg ”.

The pressure force F_p is exerted on the fluid mass, if there exists a pressure gradient between the two points in the direction of the flow.

The viscous force F_v is due to the viscosity of the flowing fluid and thus exists in case of all real fluids.

The turbulent flow F_t is due to the turbulence of the fluid flow.

The compressibility force F_c is due to the elastic property of the fluid and it is important only for compressible fluids.

If a certain mass of fluid in motion is influenced by all the above forces, then according to Newton’s second law of motion

$$\text{The net force } F_x = M \cdot a_x = (F_g)_x + (F_p)_x + (F_v)_x + (F_t)_x + (F_c)_x$$

i) if the net force due to compressibility(F_c) is negligible, the resulting net force

$$F_x = (F_g)_x + (F_p)_x + (F_v)_x + (F_t)_x \text{ and the equation of motions are called}$$

Reynolds’s equations of motion.

ii) For flow where (F_t) is negligible, the resulting equations of motion are known as

Navier – Stokes equation.

iii) If the flow is assumed to be ideal, viscous force (F_v) is zero and the equations of motion are known as **Euler’s equation of motion.**

EULER’S EQUATION OF MOTION

In this equation of motion the forces due to gravity and pressure are taken in to consideration. This is derived by considering the motion of the fluid element along a stream-line as:

Consider a stream-line in which flow is taking place in s- direction. Consider a cylindrical element of cross-section dA and length ds .

The forces acting on the cylindrical element are:

1. Pressure force $p dA$ in the direction of flow.

2. Pressure force $p + \frac{\partial p}{\partial s} ds dA$

3. Weight of element $\rho g dA \cdot ds$

Let θ is the angle between the direction of flow and the line

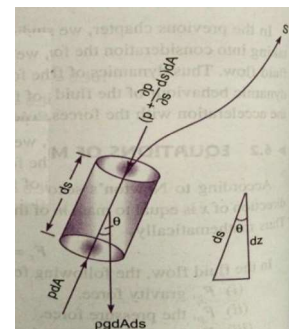

of action of the weight of the element.

The resultant force on the fluid element in the direction of S must be equal to the mass of fluid element \times acceleration in the direction of s.

$$pdA - p + \frac{\partial p}{\partial s} ds dA - \rho g dA ds \cos\theta$$

$$= \rho dA ds \times a_s \quad \text{_____ (1)}$$

Whereas is the acceleration in the direction of s.

Now $a_s = \frac{dv}{dt}$ where „v“ is a function of s and t.

$$= \frac{\partial v}{\partial s} \frac{ds}{dt} + \frac{\partial v}{\partial t} = \frac{v \partial v}{\partial s} + \frac{\partial v}{\partial t}$$

If the flow is steady, then $\frac{\partial v}{\partial t} = 0$

$$a_s = \frac{v \partial v}{\partial s}$$

Substituting the value of a_s in equation (1) and simplifying, we get

$$-\frac{\partial p}{\partial s} ds dA - \rho g dA ds \cos\theta = \rho dA ds \times \frac{v \partial v}{\partial s}$$

Dividing by $\rho dA ds$, $-\frac{1}{\rho} \times \frac{\partial p}{\partial s} - g \cos\theta = \frac{v \partial v}{\partial s}$

$$-\frac{1}{\rho} \times \frac{\partial p}{\partial s} + g \cos\theta + \frac{v \partial v}{\partial s} = 0$$

But we have $\cos\theta = \frac{dz}{ds}$

$$-\frac{1}{\rho} \times \frac{\partial p}{\partial s} + g \frac{dz}{ds} + \frac{v \partial v}{\partial s} = 0$$

$$\frac{\partial p}{\rho} + g dz + v dv = 0$$

\therefore This equation is known as Euler's equation of motion.

BERNOULLI'S EQUATION FROM EULER'S EQUATION

Bernoulli's equation is obtained by integrating the Euler's equation of motion as

$$\frac{dp}{\rho} + g dz + v dv = Constant$$

If the flow is incompressible, ρ is constant and

$$\frac{p}{\rho} + gz + \frac{v^2}{2} = constant$$

$$\frac{p}{\rho g} + z + \frac{v^2}{2g} = constant$$

$$\frac{p}{\rho g} + \frac{v^2}{2g} + z = constant$$

The above equation is Bernoulli's equation in which

$$\frac{p}{\rho g} = \text{Pressure energy per unit weight of fluid or pressure head.}$$

$$\frac{v^2}{2g} = \text{Kinetic energy per unit weight of fluid or Kinetic head.}$$

z = Potential energy per unit weight of fluid or Potential head.

The following are the assumptions made in the derivation of Bernoulli's equation.

- i. The fluid is ideal. i.e. Viscosity is zero.
- ii. The flow is steady.
- iii. The flow is incompressible.
- iv. The flow is irrotational.

MOMENTUM EQUATION

It is based on the law of conservation of momentum or on the momentum principle, which states that the net force acting on a fluid mass equal to the change in the momentum of the flow per unit time in that direction. The force acting on a fluid mass m , is given by Newton's second law of motion.

$$F = m \times a$$

Where 'a' is the acceleration acting in the same direction as force

$$F. \text{ But } a = \frac{dv}{dt}$$
$$F = m \frac{dv}{dt} = \frac{d(mv)}{dt} \quad (\text{Since } m \text{ is a constant and can be taken inside differential})$$
$$F = \frac{d(mv)}{dt} \quad \text{is known as the momentum principle.}$$

$F \cdot dt = d(mv)$ _____ Is known as the impulse momentum equation.
It states that the impulse of a force F acting on a fluid mass m in a short interval of time dt is equal to the change of momentum $d(mv)$ in the direction of force.

Force exerted by a flowing fluid on a pipe-bend:

The impulse momentum equation is used to determine the resultant force exerted by a flowing fluid on a pipe bend.

Consider two sections (1) and (2) as above

Let v_1 = Velocity of flow at section (1)

P_1 = Pressure intensity at section (1)

A_1 = Area of cross-section of pipe at section (1)

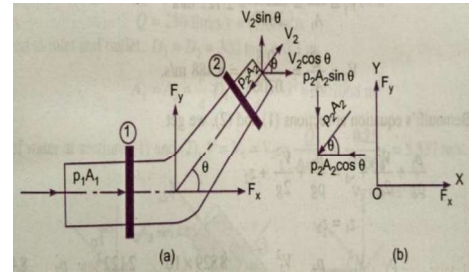

And V_2, P_2, A_2 are corresponding values of Velocity, Pressure, Area at section (2)

Let F_x and F_y be the components of the forces exerted by the flowing fluid on the bend in x and y directions respectively. Then the force exerted by the bend on the fluid in the directions of x and y will be equal to F_x and F_y but in the opposite directions. Hence the component of the force exerted by the bend on the fluid in the x – direction = $- F_x$ and in the direction of $y = - F_y$. The other external forces acting on the fluid are $p_1 A_1$ and $p_2 A_2$ on the sections (1) and (2) respectively. Then the momentum equation in x -direction is given by

Net force acting on the fluid in the direction of x = Rate of change of momentum in x –direction

$$\begin{aligned}
 p_1 A_1 - p_2 A_2 \cos \theta - F_x &= (\text{Mass per second}) (\text{Change of velocity}) \\
 &= \rho Q (\text{Final velocity in } x\text{-direction} - \text{Initial velocity in } x\text{-direction}) \\
 &= \rho Q (V_2 \cos \theta - V_1) \\
 F_x &= \rho Q (V_1 - V_2 \cos \theta) + p_1 A_1 - p_2 A_2 \cos \theta \text{ _____ (1)}
 \end{aligned}$$

Similarly the momentum equation in y -direction gives

$$\begin{aligned}
 0 - p_2 A_2 \sin \theta - F_y &= \rho Q (V_2 \sin \theta - 0) \\
 F_y &= \rho Q (-V_2 \sin \theta) - p_2 A_2 \sin \theta \text{ _____ (2)}
 \end{aligned}$$

Now the resultant force (F_R) acting on the bend

$$F_R = \sqrt{F_x^2 + F_y^2}$$

And the angle made by the resultant force with the horizontal direction is given by

$$\tan \theta = \frac{F_y}{F_x}$$

PROBLEMS

1. The diameter of a pipe at sections 1 and 2 are 10 cm and 15cms respectively. Find the discharge through pipe, if the velocity of water flowing through the pipe at section 1 is 5m/sec. determine the velocity at section 2.

Given:

At section 1,

$$D_1 = 10\text{cms} = 0.1\text{m}$$

$$A_1 = \frac{\pi D_1^2}{4} = \frac{\pi (0.1)^2}{4} = 0.007854 \text{ m}^2$$

$$V_1 = 5\text{m/sec}$$

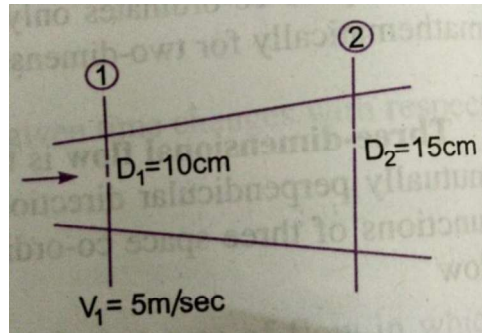

At section 2, $D_2 = 15\text{cms} = 0.15\text{m}$

$$A_2 = \frac{\pi (0.15)^2}{4} = 0.01767 \text{ m}^2$$

Discharge through pipe $Q = A_1 \times V_1$

$$= 0.007854 \times 5 = 0.03927 \text{ m}^3/\text{sec}$$

We have

$$A_1 V_1 = A_2 V_2$$

$$V_2 = \frac{A_1 V_1}{A_2} = \frac{0.007854 \times 5.0}{0.01767} = 2.22\text{m/s}$$

2. Water is flowing through a pipe of 5cm dia. Under a pressure of 29.43N/cm² and with mean velocity of 2 m/sec. find the total head or total energy per unit weight of water at a cross-section, which is 5m above datum line.

Given: dia. Of pipe = 5cm = 0.05m

Pressure P = 29.43N/cm² = 29.43 x 10⁴N/m²

Velocity V = 2 m/sec

Datum head Z = 5m

Total head = Pressure head + Kinetic head + Datum head

$$\text{Pressure head} = \frac{P}{\rho g} = \frac{29.43 \times 10^4}{1000 \times 9.81} = 30\text{m}$$

$$\text{Kinetic head} = \frac{v^2}{2g} = \frac{2^2}{2 \times 9.81} = 0.204\text{m}$$

Datum head = $Z = 5\text{m}$

$$\frac{p}{\rho g} + \frac{V^2}{2g} + Z = 30 + 0.204 + 5 = 35.204\text{m}$$

Total head = 35.204m

3. A pipe through which water is flowing is having diameters 20cms and 10cms at cross-sections 1 and 2 respectively. The velocity of water at section 1 is 4 m/sec. Find the velocity head at section 1 and 2 and also rate of discharge?

Given: $D_1 = 20\text{cms} = 0.2\text{m}$

$$A_1 = \frac{\pi}{4} \times 0.2^2 = 0.0314\text{m}^2$$

$$V_1 = 4\text{ m/sec}$$

$$D_2 = 10\text{ cm} = 0.1\text{ m}$$

$$A_2 = \frac{\pi}{4} \times 0.1^2 = 0.007854\text{m}^2$$

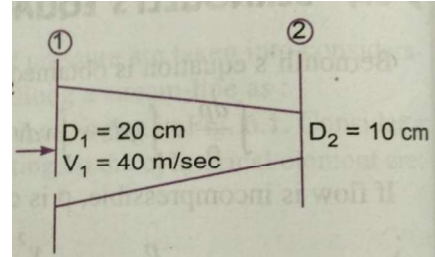

i) Velocity head at section 1 $\frac{V_1^2}{2g} = \frac{4 \times 4}{2 \times 9.81}$

0.815m

ii) Velocity head at section 2 $\frac{V_2^2}{2g}$

To find V_2 , apply continuity equation $V_1 A_1 = V_2 A_2$
 $V_2 = \frac{A_1 V_1}{A_2} = \frac{0.0314 \times 4}{0.00785} = 16\text{m/sec}$

Velocity head at section 2

$$\frac{V_2^2}{2g} = \frac{16 \times 16}{2 \times 9.81} = 13.047\text{m}$$

iii) Rate of discharge

$$Q = A_1 V_1 = A_2 V_2$$

$$= 0.0314 \times 4 = 0.1256\text{ m}^3/\text{sec}$$

Q = 125.6 Liters/sec

4. Water is flowing through a pipe having diameters 20cms and 10cms at sections 1 and 2 respectively. The rate of flow through pipe is 35 liters/sec. The section 1 is 6m above the datum and section 2 is 4m above the datum. If the pressure at section 1 is 39.24n/cm². Find the intensity of pressure at section 2?

Given: At section 1 $D_1 = 20\text{cm} = 0.2\text{m}$

$$A_1 = \frac{\pi}{4} \times 0.2^2 = 0.0314\text{m}^2$$

$$P_1 = 39.24\text{N/cm}^2 = 39.24 \times 10^4\text{N/m}^2$$

10^4N/m^2

$$Z_1 = 6\text{m}$$

At section 2 $D_2 = 10\text{cm} = 0.1\text{m}$

$$A_2 = \frac{\pi}{4} \times 0.1^2 = 0.007854\text{m}^2$$

$$Z_2 = 4\text{m},$$

$$P_2 = ?$$

Rate of flow $Q = 35\text{ lt/sec} = (35/1000)\text{ m}^3/\text{sec} = 0.035\text{ m}^3/\text{sec}$

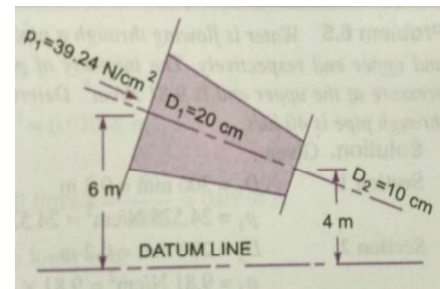

$$Q = A_1 V_1 = A_2 V_2$$

$$V_1 = \frac{Q}{A_1} = \frac{0.035}{0.0314} = 1.114\text{m/sec}$$

$$V_2 = \frac{Q}{A_2} = \frac{0.035}{0.007854} = 4.456\text{m/sec}$$

Applying Bernoulli's equation at sections 1 and 2

$$\frac{P_1}{\rho g} + \frac{V_1^2}{2g} + Z_1 = \frac{P_2}{\rho g} + \frac{V_2^2}{2g} + Z_2$$

$$39.24 \times 10^4 + \frac{1000 \times 9.81}{2 \times 9.81} + \frac{1.114^2}{2 \times 9.81} + 6 = \frac{P_2}{1000 \times 9.81} + \frac{4.456^2}{2 \times 9.81} + 4$$

$$40 + 0.063 + 6 = \frac{P_2}{9810} + 1.102 + 4$$

$$46.063 = \frac{P_2}{9810} + 5.102$$

$$\frac{P_2}{9810} = 46.063 - 5.102 = 41.051$$

$$P_2 = 41.051 \times 9810 = 402710 \text{ N/m}^2$$

$$P_2 = 40.271 \text{ N/cm}^2$$

5) Water is flowing through a pipe having diameter 300mm and 200mm at the bottom and upper end respectively. The intensity of pressure at the bottom end is 24.525N/cm² and the pressure at the upper end is 9.81N/cm². Determine the difference in datum head if the rate of flow through is 40lit/sec?

Given:

section 1 $D_1 = 300 \text{ mm} = 0.3 \text{ m}$

$$A_1 = \frac{\pi}{4} \times 0.3^2 = 0.07065 \text{ m}^2$$

$$P_1 = 24.525 \text{ N/cm}^2 = 24.525 \times 10^4 \text{ N/m}^2$$

Section 2 $D_2 = 200 \text{ mm} = 0.2 \text{ m}$

$$A_2 = \frac{\pi}{4} \times (0.2)^2 = 0.0314 \text{ m}^2$$

$$P_2 = 9.81 \text{ N/cm}^2 = 9.81 \times 10^4 \text{ N/m}^2$$

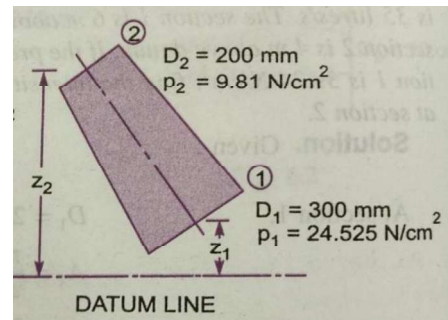

Rate of flow

$$Q = 40 \text{ lit/Sec} = 40/1000 = 0.04 \text{ m}^3/\text{sec}$$

$$Q = A_1 V_1 = A_2 V_2$$

$$V_1 = \frac{Q}{A_1} = \frac{0.04}{0.07065} = 0.566 \text{ m/sec}$$

$$V_2 = \frac{Q}{A_2} = \frac{0.04}{0.0314} = 1.274 \text{ m/sec}$$

Applying Bernoulli's equation at sections 1 and 2

$$\frac{P_1}{\rho g} + \frac{V_1^2}{2g} + Z_1 = \frac{P_2}{\rho g} + \frac{V_2^2}{2g} + Z_2$$

$$\frac{24.525 \times 10^4}{1000 \times 9.81} + \frac{0.566^2}{2 \times 9.81} + Z_1 = \frac{9.81 \times 10^4}{1000 \times 9.81} + \frac{1.274^2}{2 \times 9.81} + Z_2$$

$$25 + 0.32 + Z_1 = 10 + 1.623 + Z_2$$

$$Z_2 - Z_1 = 25.32 - 11.623 = 13.697 \text{ or say } 13.70\text{m}$$

The difference in datum head = $Z_2 - Z_1 = 13.70\text{m}$

6) The water is flowing through a taper pipe of length 100m having diameters 600mm at the upper end and 300mm at the lower end, at the rate of 50lts/sec. the pipe has a slope of 1 in 30. Find the pressure at the lower end, if the pressure at the higher level is 19.62N/cm^2 ?

Given: Length of pipe $L = 100\text{m}$
Dia. At the upper end $D_1 = 600\text{mm} = 0.6\text{m}$

$$A_1 = \frac{\pi}{4} \times 0.6^2 = 0.2827\text{m}^2$$

$$P_1 = 19.62\text{N/cm}^2 = 19.62 \times 10^4 \text{ N/m}^2$$

Dia. at the lower end $D_2 = 300\text{mm} = 0.3\text{m}$

$$A_2 = \frac{\pi}{4} \times 0.3^2 = 0.07065\text{m}^2$$

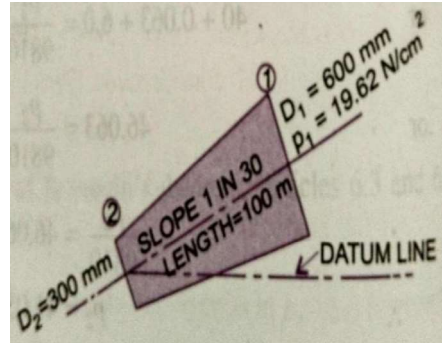

$$\text{Rate of flow } Q = 50 \text{ Lts/sec} = \frac{50}{1000} = 0.05 \text{ m}^3/\text{sec}$$

Let the datum line is passing through the centre of the lower end. Then $Z_2 = 0$

$$\text{As slope is 1 in 30 means } Z_1 = \frac{1}{30} \times 100 = \frac{10}{3}$$

We also know that $Q = A_1 V_1 = A_2 V_2$

$$V_1 = \frac{Q}{A_1} = \frac{0.05}{0.2827} = 0.177\text{m/sec}$$

$$V_2 = \frac{Q}{A_2} = \frac{0.05}{0.07065} = 0.707\text{m/sec}$$

Applying Bernoulli's equation at sections 1 and 2

$$\frac{P_1}{\rho g} + \frac{V_1^2}{2g} + Z_1 = \frac{P_2}{\rho g} + \frac{V_2^2}{2g} + Z_2$$

$$\frac{19.62 \times 10^4}{1000 \times 9.81} + \frac{0.177^2}{2 \times 9.81} + \frac{10}{3} = \frac{P_2}{1000 \times 9.81} + \frac{0.707^2}{2 \times 9.81} + 0$$

$$20 + 0.001596 + 3.334 = \frac{P_2}{9810} + 0.0254$$

$$23.335 = \frac{P_2}{9810} + 0.0254$$

$$\frac{P_2}{9810} = 23.335 - 0.0254 = 23.31$$

$$P_2 = 23.31 \times 9810 = 228573 \text{ N/m}^2$$

$$P_2 = 22.857 \text{ N/cm}^2$$

7) A 45° reducing bend is connected to a pipe line, the diameters at inlet and out let of the bend being 600mm and 300mm respectively. Find the force exerted by the water on the bend, if the intensity of pressure at the inlet to the bend is 8.829 N/cm^2 and rate of flow of water is 600 Lts/sec.

Given: Angle of bend $\theta = 45^\circ$

$$\text{Dia. at inlet } D_1 = 600 \text{ mm} = 0.6 \text{ m}$$

$$A_1 = \frac{\pi}{4} (0.6)^2 = 0.2827 \text{ m}^2$$

$$\text{Dia. at out let } D_2 = 300 \text{ mm} = 0.3 \text{ m}$$

$$A_2 = \frac{\pi}{4} (0.3)^2 = 0.07065 \text{ m}^2$$

$$\text{Pressure at inlet } P_1 = 8.829 \text{ N/cm}^2 = 8.829 \times 10^4 \text{ N/m}^2$$

$$Q = 600 \text{ Lts/sec} = 0.6 \text{ m}^3/\text{sec}$$

$$V_1 = \frac{Q}{A_1} = \frac{0.6}{0.2827} = 2.122 \text{ m/sec}$$

$$V_2 = \frac{Q}{A_2} = \frac{0.6}{0.07065} = 8.488 \text{ m/sec}$$

Applying Bernoulli's equation at sections 1 and 2, we get

$$\frac{P_1}{\rho g} + \frac{V_1^2}{2g} + Z_1 = \frac{P_2}{\rho g} + \frac{V_2^2}{2g} + Z_2$$

But $Z_1 = Z_2$, then

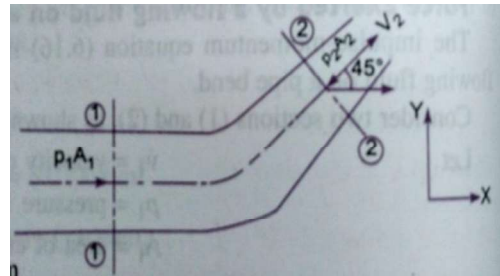

$$\frac{8.829 \times 10^4}{1000 \times 9.81} + \frac{2.122^2}{2 \times 9.81} = \frac{P_2}{1000 \times 9.81} + \frac{8.488^2}{2 \times 9.81}$$

$$9 + 0.2295 = \frac{P_2}{9810} + 3.672 \quad \frac{P_2}{9810} = 9.2295 - 3.672 = 5.5575 \text{ m of water}$$

$$P_2 = 5.5575 \times 9810 = 5.45 \times 10^4 \text{ N/m}^2$$

Force exerted on the bend in X and Y – directions

$$\begin{aligned} F_x &= \rho Q (V_1 - V_2 \cos \theta) + P_1 A_1 - P_2 A_2 \cos \theta \\ &= 1000 \times 0.6 (2.122 - 8.488 \cos 45^\circ) + 8.829 \times 10^4 \times 0.2827 - 5.45 \times 10^4 \times 0.07065 \times \cos 45^\circ \\ &= -2327.9 + 24959.6 - 2720.3 = 24959.6 - 5048.2 = 19911.4 \text{ N} \end{aligned}$$

$$\mathbf{F_x = 19911.4 \text{ N}}$$

$$\begin{aligned} F_y &= \rho Q (-V_2 \sin \theta) - P_2 A_2 \sin \theta \\ &= 1000 \times 0.6 (-8.488 \sin 45^\circ) - 5.45 \times 10^4 \times 0.07068 \sin 45^\circ \\ &= -3601.1 - 2721.1 = -6322.2 \text{ N} \end{aligned}$$

(-ve sign means F_y is acting in the down ward direction)

$$\mathbf{F_y = - 6322.2 \text{ N}}$$

$$\text{Therefore the Resultant Force } F_R = \sqrt{F_x^2 + F_y^2} = \sqrt{(19911.4)^2 + (-6322.2)^2} = 20890.9 \text{ N}$$

$$\mathbf{F_R = 20890.9 \text{ N}}$$

$$\begin{aligned} \text{The angle made by resultant force with X – axis is } \tan \theta &= \frac{F_x}{F_y} \\ &= (6322.2/19911.4) = 0.3175 \end{aligned}$$

$$\mathbf{\theta = \tan^{-1}0.3175 = 17^\circ 36'}$$

UNIT-3

BOUNDARY LAYER

Boundary Layer Characteristics

The concept of boundary layer was first introduced by a German scientist, Ludwig Prandtl, in the year 1904. Although, the complete descriptions of motion of a viscous fluid were known through Navier-Stokes equations, the mathematical difficulties in solving these equations prohibited the theoretical analysis of viscous flow. Prandtl suggested that the viscous flows can be analyzed by dividing the flow into two regions; one close to the solid boundaries and other covering the rest of the flow. Boundary layer is the regions close to the solid boundary where the effects of viscosity are experienced by the flow. In the regions outside the boundary layer, the effect of viscosity is negligible and the fluid is treated as inviscid. So, the boundary layer is a buffer region between the wall below and the inviscid free-stream above. This approach allows the complete solution of viscous fluid flows which would have been impossible through Navier-Stokes equation. The qualitative picture of the boundary-layer growth over a flat plate is shown in Fig. 1.

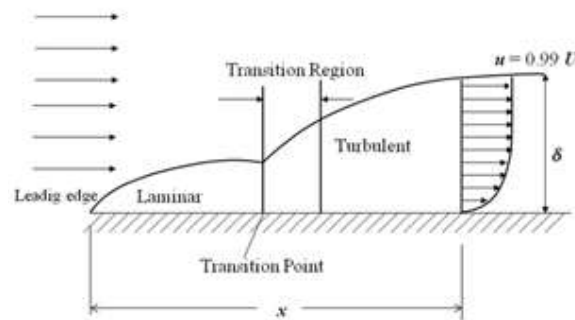

Fig. 1: Representation of boundary layer on a flat plate.

A laminar boundary layer is initiated at the leading edge of the plate for a short distance and extends to downstream. The transition occurs over a region, after certain length in the downstream followed by fully turbulent boundary layers. For common calculation purposes, the transition is usually considered to occur at a distance where the Reynolds number is about 500,000. With air at standard conditions, moving at a velocity of 30m/s, the transition is expected to occur at a distance of about 250mm. A typical boundary layer flow is characterized by certain parameters as given below;

Boundary layer thickness: It is known that no-slip conditions have to be satisfied at the solid surface: the fluid must attain the zero velocity at the wall. Subsequently, above the wall, the effect of viscosity tends to reduce and the fluid within this layer will try to approach the free stream velocity. Thus, there is a velocity gradient that develops within the fluid layers inside the small regions near to solid surface. The *boundary layer thickness* is defined as the distance from the surface to a point where the velocity reaches 99% of the free stream velocity. Thus, the velocity profile merges smoothly and asymptotically into the free stream as shown in Fig. 2.

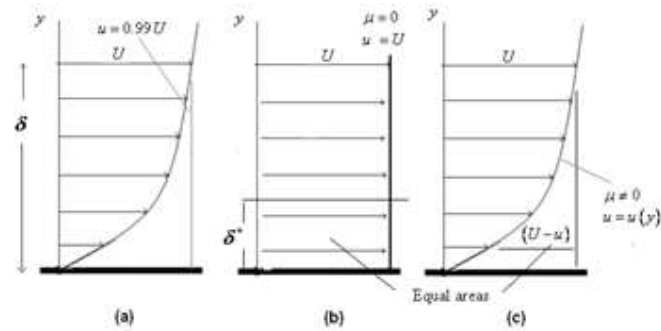

Fig. 5.7.3: (a) Boundary layer thickness; (b) Free stream flow (no viscosity);
(c) Concepts of displacement thickness.

Fig. 2: (a) Boundary layer thickness; (b) Free stream flow (no viscosity);

(c) Concepts of displacement thickness.

CLOSED CONDUIT FLOW:

REYNOLDS EXPERIMENT: It consists of a constant head tank filled with water, a small tank containing dye, a horizontal glass tube provided with a bell-mouthed entrance and a regulating valve. The water was made to flow from the tank through the glass tube in to the atmosphere and the velocity of flow was varied by adjusting the regulating valve. The liquid dye having the same specific weight as that of water was introduced in to the flow at the bell – mouth through a small tube

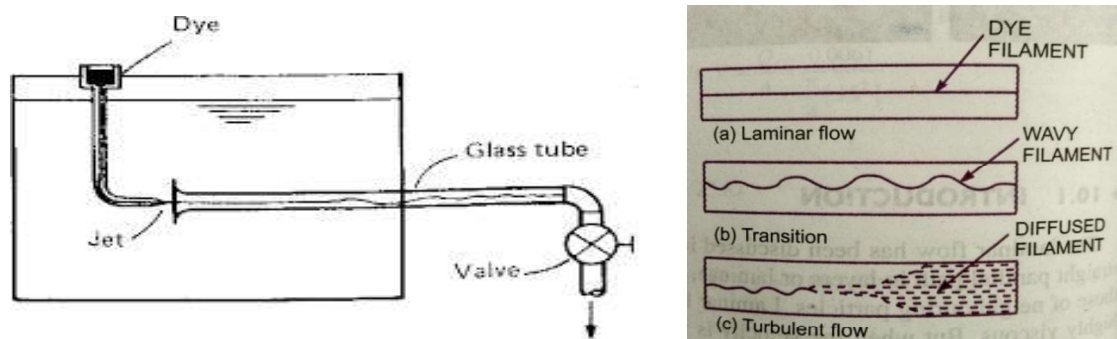

From the experiments it was disclosed that when the velocity of flow was low, the dye remained in the form of a straight line and stable filament passing through the glass tube so steady that it scarcely seemed to be in motion with increase in the velocity of flow a critical state was reached at which the filament of dye showed irregularities and began to waver. Further increase in the velocity of flow the fluctuations in the filament of dye became more intense and ultimately the dye diffused over the entire cross-section of the tube, due to intermingling of the particles of the flowing fluid

Reynolds's deduced from his experiments that at low velocities the intermingling of the fluid particles was absent and the fluid particles moved in parallel layers or lamina, sliding past the adjacent lamina but not mixing with them. This is the laminar flow. At higher velocities the dye filament diffused through the tube it was apparent that the intermingling of fluid particles was occurring in other words the flow was turbulent. The velocity at which the flow changes from the laminar to turbulent for the case of a given fluid at a given temperature and in a given pipe is known as Critical Velocity. The state of flow in between these types of flow is known as transitional state or flow in transition.

Reynolds discovered that the occurrence of laminar and turbulent flow was governed by the relative magnitudes of the inertia and the viscous forces. At low velocities the viscous forces become predominant and flow is viscous. At higher velocities of flow the inertial forces predominance over viscous forces. Reynolds related the inertia to viscous forces and arrived at a dimension less parameter.

$$R_e \text{ or } N_R = \frac{\text{inertia force}}{\text{viscous force}} = \frac{F_i}{F_v}$$

According to Newton's 2nd law of motion, the inertia force F_i is given by

$$\begin{aligned} F_i &= \text{mass} \times \text{acceleration} \\ &= \rho \times \text{volume} \times \text{acceleration} && \rho = \text{mass density} \\ &= \rho \times L^3 \times \frac{L}{T^2} = \rho L^2 V^2 && \text{----- (1)} && L = \text{Linear dimension} \end{aligned}$$

Similarly viscous force F_v is given by Newton's 2nd law of velocity as

$$\begin{aligned} F_v &= \tau \times \text{area} && \tau = \text{shear stress} \\ &= \mu \frac{dv}{dy} \times L^2 = \mu VL && \text{----- (2)} && V = \text{Average Velocity of flow} \\ &&& && \mu = \text{Viscosity of fluid} \end{aligned}$$

$$R_e \text{ or } N_R = \frac{\rho L^2 V^2}{\mu VL} = \frac{\rho VL}{\mu}$$

In case of pipes $L = D$

$$\text{In case of flow through pipes } R_e = \frac{\rho DV}{\mu} \text{ or } \frac{VD}{\nu}$$

Where μ/ρ = kinematic viscosity of the flowing liquid v

The Reynolds number is a very useful parameter in predicting whether the flow is laminar or turbulent.

$R_e < 2000$ viscous / laminar flow

$R_e \rightarrow 2000$ to 4000 transient flow

$R_e > 4000$ Turbulent flow

FRICIONAL LOSS IN PIPE FLOW - DARCY WEISBACK EQUATION

When a liquid is flowing through a pipe, the velocity of the liquid layer adjacent to the pipe wall is zero. The velocity of liquid goes on increasing from the wall and thus velocity gradient and hence shear stresses are produced in the whole liquid due to viscosity. This viscous action causes loss of energy, which is known as frictional loss.

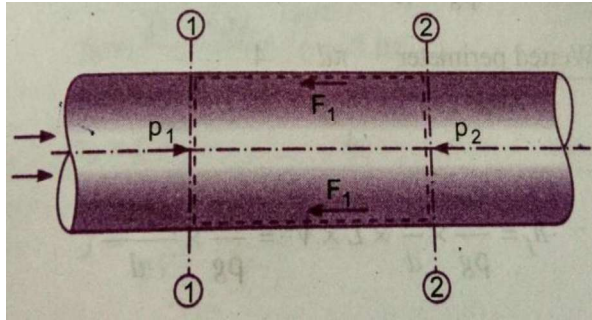

Consider a uniform horizontal pipe having steady flow. Let 1-1, 2-2 are two sections of pipe.

- Let
- P_1 = Pressure intensity at section 1-1
 - V_1 = Velocity of flow at section 1-1
 - L = Length of pipe between section 1-1 and 2-2
 - d = Diameter of pipe
 - f' = Fractional resistance for unit wetted area per a unit velocity
 - h_f = Loss of head due to friction

And P_2, V_2 = are values of pressure intensity and velocity at section 2-2

Applying Bernoulli's equation between sections 1-1 and 2-2

Total head at 1-1 = total head at 2-2 + loss of head due to friction between 1-1 and 2-2

$$\frac{P_1}{\rho g} + \frac{V_1^2}{2g} + Z_1 = \frac{P_2}{\rho g} + \frac{V_2^2}{2g} + Z_2 + h_f$$

$Z_1 = Z_2$ as pipe is horizontal

$V_1 = V_2$ as dia. of pipe is same at 1-1 and 2-2

$$\frac{P_1}{\rho g} = \frac{P_2}{\rho g} + h_f \quad \text{Or}$$

$$h_f = \frac{P_1}{\rho g} - \frac{P_2}{\rho g} \quad \text{-----(1)}$$

But h_f is head is lost due to friction and hence the intensity of pressure will be reduced in the direction flow by frictional resistance.

Now, Frictional Resistance = Frictional resistance per unit wetted area per unit velocity
 \times Wetted Area \times (velocity)²

$$F_1 = f' \times \pi d L \times V^2 \quad [\because \text{Wetted area} = \pi d \times L, \text{ Velocity} = V = V_1 = V_2]$$

$$F_1 = f' \times p L V^2 \text{ (2)} \quad [\because \pi d = \text{perimeter} = p]$$

The forces acting on the fluid between section 1-1 and 2-2 are

Pressure force at section 1-1 = $P_1 \times A$ where A = area of pipe

Pressure force at section 2-2 = $P_2 \times A$

Frictional force = F_1

Resolving all forces in the horizontal direction, we have

$$P_1 A - P_2 A - F_1 = 0$$

$$(P_1 - P_2)A = F_1 = f' \times p \times L \times V^2 \quad \text{from equation - (2)}$$

$$P_1 - P_2 = \frac{f' \times p \times L \times V^2}{A} \quad \text{But from equation (1) } P_1 - P_2 = \rho g h_f$$

Equating the value of $P_1 - P_2$, we get

$$\rho g h_f = \frac{f' \times p \times L \times V^2}{A}$$

$$\boxed{?} h_f = \frac{f'}{\rho g} \times \frac{p}{A} \times L \times V^2 \text{ (3)}$$

In the equation (3) $\frac{p}{A} = \frac{\text{Wetted Perimeter}}{\text{Area}} = \frac{\pi d}{\frac{\pi d^2}{4}} = \frac{4}{d}$

$$\boxed{?} h_f \equiv \frac{f'}{\rho g} \times \frac{4}{d} \times L \times V^2 = \frac{f'}{\rho g} \times \frac{4LV^2}{d}$$

Putting $\frac{f'}{\rho} = \frac{f}{2}$ Where f is known as co-efficient of friction.

Equation (4) becomes as
$$h_f = \frac{4f}{2g} \times \frac{LV^2}{d}$$

$$h_f = \frac{4fLV^2}{2gd}$$

This Equation is known as Darcy – Weisbach equation, commonly used for finding loss of head due to friction in pipes

Then f is known as a friction factor or co-efficient of friction which is a dimensionless quantity. f is not a constant but, its value depends upon the roughness condition of pipe surface and the Reynolds number of the flow.

MINOR LOSSES IN PIPES:

The loss of energy due to friction is classified as a major loss, because in case of long pipe lines it is much more than the loss of energy incurred by other causes.

The minor losses of energy are caused on account of the change in the velocity of flowing fluids (either in magnitude or direction). In case of long pipes these losses are quite small as compared with the loss of energy due to friction and hence these are termed as „minor losses „

Which may even be neglected without serious error However in short pipes these losses may sometimes outweigh the friction loss. Some of the losses of energy which may be caused due to the change of velocity are:

- 1 Loss of energy due to sudden enlargement $= \frac{V_1 - V_2^2}{2g}$
 $= 0.5 \frac{V_2^2}{2g}$
- 2 Loss of energy due to sudden contraction $= \frac{c}{2g} V^2$
- 3 Loss of energy at the entrance to a pipe $= 0.5 \frac{V^2}{2g}$
- 4 Loss of energy at the exit from a pipe $= \frac{V^2}{2g}$
- 5 Loss of energy due to gradual contraction or enlargement $= \frac{k V_1 - V_2^2}{2g}$
- 6 Loss of energy in the bends $= \frac{kV^2}{2g}$
- 7 Loss of energy in various pipe fittings

$$= \frac{kV^2}{2g}$$

—

1. LOSS OF HEAD DUE TO SUDDEN ENLARGEMENT

Consider a liquid flowing through a pipe which has sudden enlargement. Consider two sections 1-1 and 2-2 before and after enlargement. Due to sudden change of diameter of the pipe from D_1 to D_2 , the liquid flowing from the smaller pipe is not able to follow the abrupt change of the boundary. Thus the flow separates from the boundary and turbulent eddies are formed. The loss of head takes place due to the formation of these eddies.

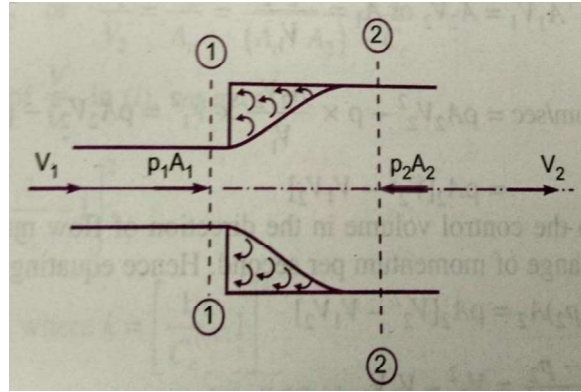

Let p' = Pressure intensity of the liquid eddies on the area $(A_2 - A_1)$

h_e = loss of head due to the sudden enlargement.

Applying Bernoulli's equation at section 1-1 and 2-2

$$\frac{p_1}{\rho g} + \frac{V_1^2}{2g} + z_1 = \frac{p_2}{\rho g} + \frac{V_2^2}{2g} + z_2 + \text{Loss of head due to sudden enlargement}$$

But $z_1 = z_2$ as pipe is horizontal

$$\frac{p_1}{\rho g} + \frac{V_1^2}{2g} = \frac{p_2}{\rho g} + \frac{V_2^2}{2g} + \boxed{?}$$

Or
$$\boxed{?} = \frac{p_1}{\rho g} - \frac{p_2}{\rho g} + \frac{V_1^2}{2g} - \frac{V_2^2}{2g} \quad (1)$$

The force acting on the liquid in the control volume in the direction of flow

$$F_x = p_1 A_1 + p' A_2 - A_1 - p_2 A_2$$

But experimentally it is found that $p' = p_1$

$$\begin{aligned} F_x &= p_1 A_1 + p_1 A_2 - A_1 - p_2 A_2 \\ &= p_1 A_2 - p_2 A_2 \\ &= (p_1 - p_2) A_2 \end{aligned} \quad (2)$$

Momentum of liquid/ second at section 1-1 = mass \times velocity

$$\begin{aligned} &= \rho A_1 V_1 \times V_1 \\ &= \rho A_1 V_1^2 \end{aligned}$$

Momentum of liquid/ second at section 2-2 $\rho A_2 V_2 \times V_2 = \rho A_2 V_2^2$

Change of momentum/second = $\rho A_2 V_2^2 - \rho A_1 V_1^2$ _____ (3)

But from continuity equation, we have

$$A_1 V_1 = A_2 V_2$$

Or
$$A_1 = \frac{A_2 V_2}{V_1}$$

$$\begin{aligned} \therefore \text{Change of momentum/sec} &= \rho A V_2^2 - \rho \times \frac{A_2 V_2}{V_1} \times V_1^2 \\ &= \rho A_2 V_2^2 - \rho A_1 V_1 V_2 \\ &= \rho A_2 V_2^2 - V_1 V_2 \text{-----(4)} \end{aligned}$$

Now the net force acting on the control volume in the direction of flow must be equal to rate of change of momentum per second. Hence equating equation (2) and equation (4)

$$p_1 - p_2 A_2 = \rho A_2 V_2^2 - V_1 V_2$$

$$\frac{p_1 - p_2}{\rho} = V_2^2 - V_1 V_2$$

Dividing both sides by „g“ we have
$$\frac{p_1 - p_2}{\rho g} = \frac{V_2^2 - V_1 V_2}{g}$$

Or
$$\frac{p_1}{\rho g} - \frac{p_2}{\rho g} = \frac{V_2^2 - V_1 V_2}{g}$$

Substituting in equation (1)

$$\begin{aligned} \frac{V_1^2}{2g} - \frac{V_2^2}{2g} &= \frac{V_2^2 - V_1 V_2}{g} + \frac{V_2^2 - 2V_2^2 - 2V_1 V_2 + V_1 - V_2}{2g} \\ &= \frac{V_1^2 + V_2^2 - 2V_1 V_2}{2g} \\ \frac{V_1 - V_2}{2g} &= \frac{V_1 - V_2}{2g} \end{aligned}$$

2. LOSS OF HEAD DUE TO SUDDEN CONTRACTION

Consider a liquid flowing in a pipe, which has a sudden contraction in area. Consider two sections 1-1 and 2-2 before and after contraction. As the liquid flows from larger pipe to smaller pipe, the area of flow goes on decreasing and becomes minimum at section C - C. This section is called Vena-contracta. After section C-C, a sudden enlargement of area takes place. The loss of head due to sudden contraction is actually due to sudden enlargement of area from vena-contracta to smaller pipe.

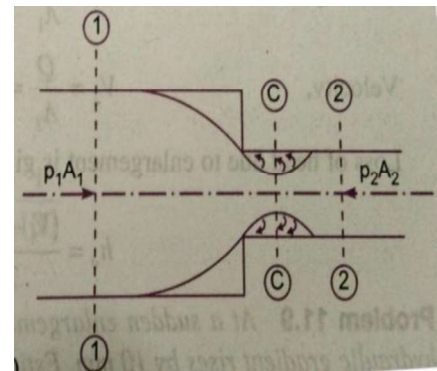

Let A_c = Area of flow at section C - C

V_c = Velocity of flow at section C - C

A_2 = Area of flow at section 2 - 2

V_2 = Velocity of flow at section 2 - 2

h_c = Loss of head due to sudden contraction

Now, h_c = Actual loss of head due to sudden enlargement from section C - C to section 2-2 is

$$h_c = \frac{V_c - V_2^2}{2g} = \frac{V_2^2}{2g} \left(\frac{V_c}{V_2} - 1 \right)^2 \quad (1)$$

From continuity equation, we have

$$A_c V_c = A_2 V_2 \quad \text{Or} \quad \frac{V_c}{V_2} = \frac{A_2}{A_c} = \frac{1}{C_c} = \frac{1}{C_c} \quad \therefore \frac{V_c}{V_2} = \frac{A_2}{A_c}$$

Substituting the value of $\frac{V_c}{V_2}$ in equation (1)

$$h_c = \frac{V_2^2}{2g} \left(\frac{1}{C_c} - 1 \right)^2 = \frac{k V_2^2}{2g}, \quad \text{Where } k = \left(\frac{1}{C_c} - 1 \right)^2$$

If the value of C_c is assumed to be equal to 0.62, then

$$k = \left(\frac{1}{0.62} - 1 \right)^2 = 0.375$$

Then h_c becomes as

$$h_c = \frac{0.375 V_2^2}{2g} = 0.375 \frac{V_2^2}{2g}$$

If the value of C_c is not given, then the head loss due to contraction is taken as

$$= 0.5 \frac{V_2^2}{2g}$$

3. LOSS OF HEAD AT THE ENTRANCE OF A PIPE

This is the loss of energy which occurs when a liquid enters a pipe which is connected to a large tank or reservoir. This loss is similar to the loss of head due to sudden contraction. This loss depends on the form of entrance. For a sharp edge entrance, this loss is slightly more than a rounded or bell mouthed entrance. In practice the value of loss of head at the entrance. In practice the value of loss of head at the entrance (inlet) of a pipe with sharp cornered entrance is taken as $0.5 \frac{v^2}{2g}$ where v = velocity of liquid in pipe. This loss is denoted by h_f

$$h_f = 0.5 \frac{v^2}{2g}$$

4. LOSS OF HEAD AT THE EXIT OF A PIPE

This loss of head (or energy) due to the velocity of the liquid at the out let of the pipe, which is dissipated either in the form of a free jet (if the out let of the pipe is free) or it is lost in the tank or reservoir. This loss is equal to $\frac{V^2}{2g}$, where V is the velocity of liquid at the out let of the pipe. This loss is denoted by h_o .

$$h_o = \frac{V^2}{2g} \quad V = \text{velocity at outlet of the pipe}$$

5. LOSS OF HEAD DUE TO OBSTRUCTION IN A PIPE

Whenever there is an obstruction in a pipe, the loss of energy takes place due to reduction of the area of the cross section of the pipe at the place where obstruction is present. There is a sudden enlargement of the area of flow beyond the obstruction due to which loss of head takes place.

Consider a pipe of area of cross-section A having an obstruction

Let a = max. Area of obstruction
 A = Area of pipe
 V = velocity of liquid in pipe

Then $(A - a)$ = Area of flow of liquid at section 1-1

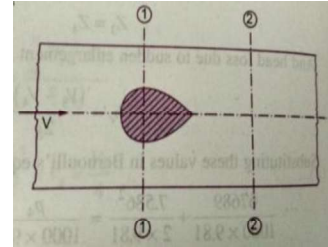

As the liquid flows and passes through section 1-1, a vena-contracta is formed beyond section 1-1- after which the stream of liquid widens again and velocity of flow at section on 2-2 become uniform and equal to velocity, v in the pipe. This situation is similar to the flow of liquid through sudden enlargement.

Let V_c = velocity of liquid at vena-contracta

Then loss of head due to obstruction = loss of head due to enlargement from vena-contracta to section 2-2

$$= \frac{V_c - V^2}{2g} \text{----- (1)}$$

From continuity equation we have $(A - a) V_c = A \times V$ ----- (2)

Where a_c = Area of cross section at vena-contracta

If C_c = co-efficient of contraction

$$\text{Then } C_c = \frac{\text{area at vena-contracta}}{A - a} = \frac{a_c}{A - a}$$

$$a_c = C_c (A - a)$$

Substituting this value in equation (2) $C_c (A - a) V_c = A V$

$$\therefore V_c = \frac{A \times V}{C_c A - a}$$

Substituting this value of V_c in equation (1)

$$\text{Head loss due to obstruction} = \frac{V_c - V^2}{2g} = \frac{\frac{A \times V}{C_c A - a} - V^2}{2g} = \frac{V^2}{2g} \frac{A}{A - a C_c}$$

6. LOSS OF HEAD DUE TO BEND IN PIPE:

When there is a bend in a pipe, the velocity flow changes, due to which separation of the flow from the boundary and also formation of eddies takes place, thus the energy is lost.

Loss of head in pipe due to bend is expressed as

$$h_b = \frac{kV^2}{2g}$$

Where, h_b = Loss of head due to bend, V = Velocity of flow, k = Co-efficient of bend.

The value of k depends on

1. Angle of bend,
2. Radius of curvature of bend,
3. Diameter of pipe.

7. LOSS OF HEAD IN VARIOUS PIPE FITTINGS:

The loss of head in various pipe fittings such as valves, couplings etc. is expressed as

$$h_b = \frac{kV^2}{2g}$$

Where V = Velocity of flow, k = co-efficient of pipe fitting.

LOSS OF ENERGY DUE TO GRADUAL CONTRACTION OR ENLARGEMENT:

The loss of energy can be considerably reduced if in place of a sudden contraction or sudden enlargement a gradual contraction or gradual enlargement is provided. This is because in gradual contraction or enlargement the velocity of flow is gradually increased or reduced, the formation of eddies responsible for dissipation of energy are eliminated.

The loss of head in gradual contraction or gradual enlargement is expressed as

$$h_L = \frac{k V_1 - V_2^2}{2g}$$

Where k is a co-efficient and V_1 and V_2 are the mean velocities at the inlet and the outlet the value of K depends on the angle of convergence or divergence and on the ratio of the upstream and the downstream cross-sectional areas. For gradual contraction the value of K is very small even for larger values of the angle of convergence. For gradual contraction without sharp corners the loss of energy caused is so small that it may be neglected.

For gradual enlargement the value of K depends on the angle of divergence.

The value of K increases as the angle of divergence increases for a given ratio of the cross-sectional areas at the inlet and at the outlet. In the case of gradual enlargement, except for very small angles of divergence, the flow of fluid is always subjected to separation from the boundaries and consequent formation of the eddies resulting in loss of energy. Therefore in the case of gradual enlargement the loss of energy can't be completely eliminated.

PIPES IN SERIES:

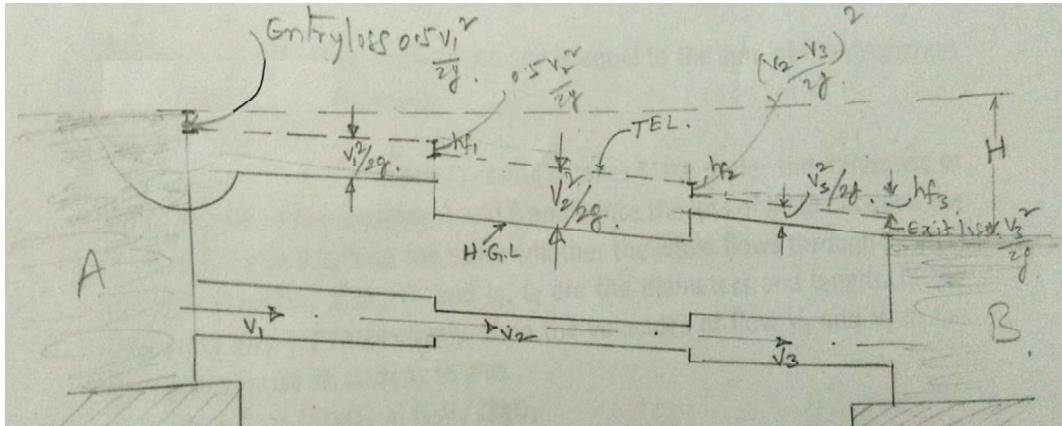

If a pipe line connecting two reservoirs is made up of several pipes of different diameters d_1 , d_2 , d_3 , etc. and lengths L_1 , L_2 , L_3 etc. all connected in series (i.e. end to end), then the difference in the liquid surface levels is equal to the sum of the head losses in all the sections. Further the discharge through each pipe will be same.

$$H = \frac{0.5V_1^2}{2g} + \frac{4f_1L_1V_1^2}{2gd_1} + \frac{0.5V_2^2}{2g} + \frac{4f_2L_2V_2^2}{2gd_2} + \frac{0.5V_3^2}{2g} + \frac{4f_3L_3V_3^2}{2gd_3}$$

Also
$$Q = \frac{\pi \times d_1^2}{4} \times V_1 = \frac{\pi \times d_2^2}{4} \times V_2 = \frac{\pi \times d_3^2}{4} \times V_3$$

However if the minor losses are neglected as compared with the loss of head due to friction in each pipe, then

$$H = \frac{4f_1L_1V_1^2}{2gd_1} + \frac{4f_2L_2V_2^2}{2gd_2} + \frac{4f_3L_3V_3^2}{2gd_3}$$

The above equation may be used to solve the problems of pipe lines in series. There are two types of problems which may arise for the pipe lines in series. Viz.

- Given a discharge Q to determine the head H and
- Given H to determine discharge Q .

If the co-efficient of friction is same for all the pipes i.e. $f_1 = f_2 = f_3$, then

$$H = \frac{4f_1L_1V_1^2}{2g d_1} + \frac{L_2V_2^2}{d_2} + \frac{L_3V_3^2}{d_3}$$

PIPES IN PARALLEL:

When a main pipeline divides into two or more parallel pipes, which may again join together downstream and continue as main line, the pipes are said to be in parallel. The pipes are connected in parallel in order to increase the discharge passing through the main. It is analogous to parallel electric current in which the drop in potential and flow of electric current can be compared to head loss and rate of discharge in a fluid flow respectively.

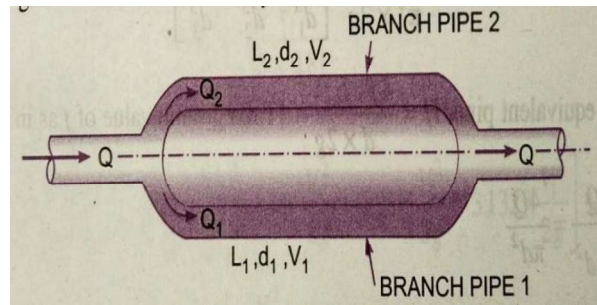

The rate of discharge in the main line is equal to the sum of the discharges in each of the parallel pipes.

$$\text{Thus } Q = Q_1 + Q_2$$

The flow of liquid in pipes (1) and (2) takes place under the difference of head between the sections A and B and hence the loss of head between the sections A and B will be the same whether the liquid flows through pipe (1) or pipe (2). Thus if D_1, D_2 and L_1, L_2 are the diameters and lengths of the pipes (1) and (2) respectively, then the velocities of flow V_1 and V_2 in the two pipes must be such as to give

$$\boxed{2} f = \frac{fL_1V_1^2}{2gd_1} = \frac{fL_2V_2^2}{2gd_2}$$

Assuming same value of f for each parallel pipe

$$\frac{L_1V_1^2}{2gd_1} = \frac{L_2V_2^2}{2gd_2}$$

HYDRAULIC GRADIENT LINE AND TOTAL ENERGY LINE:

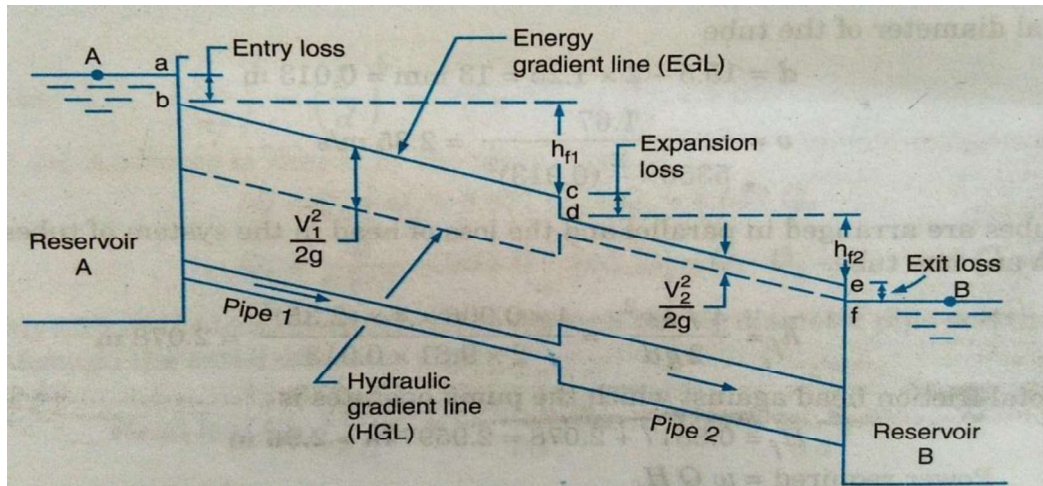

Consider a long pipe line carrying liquid from a reservoir A to reservoir B. At several points along the pipeline let piezo meters be installed. The liquid will rise in the piezometers to certain heights corresponding to the pressure intensity at each section. The height of the liquid surface above the axis of the pipe in the piezometer at any section will be equal to the pressure head (p/w) at that section. On account of loss of energy due to friction, the pressure head will decrease gradually from section to section of pipe in the direction of flow. If the pressure heads at the different sections of the pipe are plotted to scale as vertical ordinates above the axis of the pipe and all these points are joined by a straight line, a sloping line is obtained, which is known as Hydraulic Gradient Line (H.G.L).

Since at any section of pipe the vertical distance between the pipe axis and Hydraulic gradient line is equal to the pressure head at that section, it is also known as pressure line. Moreover if Z is the height of the pipe axis at any section above an arbitrary datum, then the vertical height of the Hydraulic gradient line above the datum at that section of pipe represents the piezometric head equal to $(p/w + z)$. Sometimes the Hydraulic gradient line is also known as piezometric head line.

At the entrance section of the pipe for some distance the Hydraulic gradient line is not very well defined. This is because as liquid from the reservoir enters the pipe, a sudden drop in pressure head takes place in this portion of pipe. Further the exit section of pipe being submerged, the pressure head at this section is equal to the height of the liquid surface in the reservoir B and hence the hydraulic gradient line at the exit section of pipe will meet the liquid surface in the reservoir B.

If at different sections of pipe the total energy (in terms of head) is plotted to scale as vertical ordinate above the assumed datum and all these points are joined, then a straight sloping line will be obtained and is known as energy grade line or Total energy line (T.E.L). Since total energy at any section is the sum of the pressure head (p/w), datum head z and velocity head $\frac{V^2}{2g}$ and the vertical distance between the datum and hydraulic grade line is equal to the piezometric head ($p/w + z$), the energy grade line will be parallel to the hydraulic grade line, with a vertical distance between them equal to $\frac{V^2}{2g}$. at the entrance section of the

pipe there occurs some loss of energy called “Entrance loss” equal to $h_L = 0.5 \frac{V^2}{2g}$ and hence the energy grade line at this section will lie at a vertical depth equal to $0.5 \frac{V^2}{2g}$ below the liquid surface in the reservoir A. Similarly at the exit section of pipe, since there occurs an exit loss equal to $h_L = \frac{V^2}{2g}$. The energy gradient line at this section will lie at a vertical distance equal to $\frac{V^2}{2g}$ above the liquid surface in the reservoir B. Since at any section of pipe the vertical distance between the energy grade line and the horizontal line drawn through the liquid surface in reservoir A will represent the total loss of energy incurred up to that section.

If the pipe line connecting the two reservoirs is horizontal, then the datum may be assumed to be along the pipe axis only. The piezometric head and the pressure head will then become the same.

If a pipe line carrying liquid from reservoir A discharges freely in to the atmosphere at its exit end, the hydraulic grade line at the exit end of the pipe will pass through the centre line of the pipe, since the pressure head at the exit end of the pipe will be zero (being atmospheric). The energy grade line will again be parallel to the hydraulic grade line and it will be at a vertical distance of $\frac{V^2}{2g}$ above the Hydraulic grade line

PITOT – TUBE

A Pitot tube is a simple device used for measuring the velocity of flow. The basic principle used in this is that if the velocity of flow at a particular point is reduced to zero, which is known as stagnation point, the pressure there is increased due to conversion of the kinetic energy in to pressure energy and by measuring the increase in pressure energy at this point, the velocity of flow may be determined.

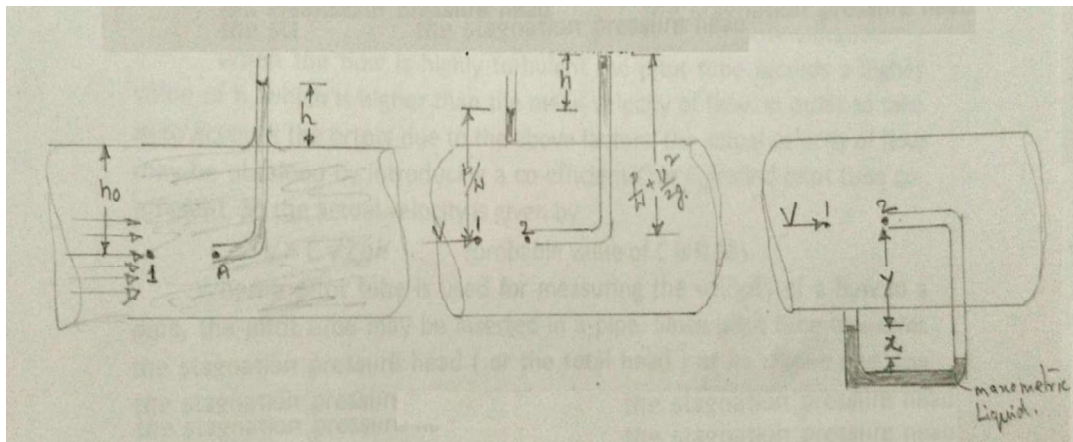

Simplest form of a pitot tube consists of a glass tube, large enough for capillary effects to be negligible and bent at right angles. A single tube of this type is used for measuring the velocity of flow in an open channel. The tube is dipped vertically in the flowing stream of fluid with its open end A directed to face the flow and other open end projecting above the fluid surface in the stream. The fluid enters the tube and the level of the

fluid in the tube exceeds that of the fluid surface in the surrounding stream. This is so because

the end A of the tube is a stagnation point, where the fluid is at rest, and the fluid approaching end A divides at this point and passes around tube. Since at stagnation point the kinetic energy is converted in to pressure energy, the fluid in the tube rises above the surrounding fluid surface by a height, which corresponds to the velocity of flow of fluid approaching end A of the tube. The pressure at the stagnation point is known as stagnation pressure.

Consider a point 1 slightly upstream of end A and lying along the same horizontal plane in the flowing stream of velocity V. Now if the point 1 and A are at a vertical depth of h_0 from the free surface of fluid and h is the height of the fluid raised in the pitot tube above the free surface of the liquid. Then by applying Bernoulli's equation between the point 1 and A, neglecting loss of energy, we get

$$\frac{P_1}{\rho} + \frac{V^2}{2g} = \frac{P_2}{\rho} + 0$$

$(h_0 + h)$ is the stagnation pressure head at a point A, which consists of static pressure head h_0 and dynamic pressure head h. Simplifying the expression,

$$\frac{V^2}{2g} = h \quad \text{Or} \quad v = \sqrt{2gh} \quad (1)$$

This equation indicates that the dynamic pressure head h is proportional to the square of the velocity of flow close to end A.

Thus the velocity of flow at any point in the flowing stream may be determined by dipping the Pitot tube to the required point and measuring the height „h“ of the fluid raised in the tube above the free surface. The velocity of flow given by the above equation (1) is more than actual velocity of flow as no loss of energy is considered in deriving the above equation.

When the flow is highly turbulent the Pitot tube records a higher value of h, which is higher than the mean velocity of flow. In order to take in to account the errors due to the above factors, the actual velocity of flow may be obtained by introducing a co-efficient C or C_v called Pitot tube co-efficient. So the actual velocity is given by

$$v = C \sqrt{2gh} \quad (\text{Probable value of C is 0.98})$$

When a pitot tube is used for measuring the velocity of a flow in a pipe, the Pitot tube may be inserted in a pipe. Since pitot tube measures the stagnation pressure head (or the total head) at its dipped end, the static pressure head is also required to be measured at the same section, where tip of pitot tube is held, in order to determine the dynamic pressure head „h“. For measuring the static pressure head a pressure tap is provided at this section to which a piezo meter may be connected. Alternatively a dynamic pressure head may also be determined directly by connecting a suitable differential manometer between the pitot tube and pressure tap.

Consider point 1 slightly up stream of the stagnation point 2.

Applying Bernoulli's equation between the points 1 and 2, we get

$$\frac{P_1}{\rho} + \frac{V^2}{2g} = \frac{P_2}{\rho} + 0 \quad (2)$$

Where P_1 and P_2 are the pressure intensities at points 1 and 2, V is velocity of flow at point 1 and ω is the specific weight of the fluid flowing through the pipe. P_1 is the static pressure and P_2 is the stagnation pressure. The equation for the pressure through the manometer in meters of water may be written as,

$$\frac{P_1}{\omega} + xs + ys + xs_m = \frac{P_2}{\omega} + s + \frac{V^2}{2g} \quad (3)$$

Where s and s_m are the specific gravities of the fluid flowing in the pipe and the manometric liquid respectively. By simplifying

$$\frac{P_2}{\omega} - \frac{P_1}{\omega} = x \left(\frac{s_m}{s} - 1 \right) + \frac{V^2}{2g}$$

After substituting for $\left(\frac{P_2}{\omega} - \frac{P_1}{\omega} \right)$ in the equation (2) and solving for V

$$= C \sqrt{2gx \left(\frac{s_m}{s} - 1 \right) + \frac{V^2}{2g}}$$

VENTURI METER

A venturi meter is a device used for measuring the rate of flow of fluid through a pipe. The basic principle on which venturi meter works is that by reducing the cross-sectional area of the flow passage, a pressure difference is created and the measurement of the pressure difference enables the determination of the discharge through the pipe.

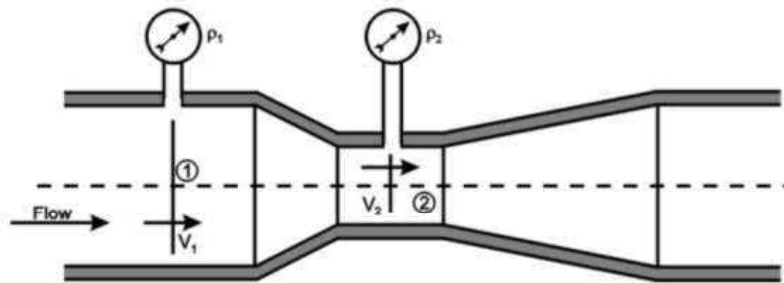

A venturi meter consists of (1) an inlet section, followed by a converging cone (2) a cylindrical throat and (3) a gradually divergent cone. The inlet section of venturi meter is the same diameter as that of the pipe which is followed by a convergent cone. The convergent cone is a short pipe, which tapers from the original size of the pipe to that of the throat of the venturi meter. The throat of the venturi meter is a short parallel – sided tube having its cross-sectional area smaller than that of the pipe. The divergent cone of the venturi meter is a gradually diverging pipe with its cross-sectional area increasing from that of the throat to the original size of the pipe. At the inlet section and the throat i.e sections 1 and 2 of the venturi meter pressure gauges are provided.

The convergent cone of the venturi meter has a total included angle of $21^\circ + 1^\circ$ and its length parallel to the axis is approx. equal to $2.7(D-d)$, where D is the dia. of pipe at inlet section and d is the dia. of the throat. The length of the throat is equal to d . The divergent cone has a total included angle 5° to 15° , preferably about 6° . This results in the convergent cone of the venturi meter to be of smaller length than its divergent cone. In the convergent cone the fluid is being accelerated from the inlet section 1 to the throat section 2, but in the divergent cone the fluid is retarded from the throat section 2 to the end section 3 of the venturi meter. The acceleration of the flowing fluid may be allowed to take place rapidly in a relatively small length without resulting in loss of energy. However if the retardation of the flow is allowed to take place rapidly in small length, then the flowing fluid will not remain in contact with the boundary of the diverging flow passage or the flow separates from the walls and eddies are formed and consequent energy loss. Therefore to avoid flow separation and consequent energy loss, the divergent cone is made longer with a gradual divergence. Since separation may occur in the divergent cone this portion is not used for discharge measurement.

Since the cross-sectional area of the throat is smaller than the cross-sectional area of the inlet section, the velocity of flow at the throat will become greater than that at inlet section, according to continuity equation. The increase in the velocity of flow at the throat results in the decrease in the pressure. As such a pressure difference is developed between the inlet section and the throat section of the venturi meter. The pressure difference between these sections can be determined either by connecting differential manometer or pressure gauges. The measurement of the pressure difference between these sections enables the rate of flow of fluid to be calculated. For greater accuracy the cross-sectional area of the throat is reduced so that the pressure at the throat is very much reduced. But if the cross-sectional area

of the throat is reduced so much that pressure drops below the vapour pressure of the flowing liquid. The formation of vapour and air pockets results in cavitation, which is not desirable. Therefore in order to avoid cavitation to occur, the diameter of the throat can be reduced to 1/3 to 3/4 of pipe diameter, more commonly the diameter of the throat is 1/2 of pipe diameter.

Let a_1 and a_2 be the cross-section areas at inlet and throat sections, at which P_1 and P_2 the pressures and velocities V_1 and V_2 respectively. Assuming the flowing fluid is incompressible and there is no loss of energy between section 1 and 2 and applying Bernoulli's equation between sections 1 and 2, we get,

$$\frac{P_1}{\omega} + \frac{v_1^2}{2g} + z_1 = \frac{P_2}{\omega} + \frac{v_2^2}{2g} + z_2$$

Where ω is the specific weight of flowing fluid.

If the venturi meter is connected in a horizontal pipe, then $Z_1 = Z_2$, then

$$\frac{P_1}{\omega} + \frac{v_1^2}{2g} = \frac{P_2}{\omega} + \frac{v_2^2}{2g}$$

$$\frac{P_1}{\omega} - \frac{P_2}{\omega} = \frac{v_2^2}{2g} - \frac{v_1^2}{2g}$$

In the above expression $\frac{P_1}{\omega} - \frac{P_2}{\omega}$ is the pressure difference between the pressure heads at section 1 and 2, is known as venturi head and is denoted by h

$$h = \frac{v_2^2}{2g} - \frac{v_1^2}{2g}$$

$$Q_{t\text{th}} = a_1 v_1 = a_2 v_2$$

$$v_1 = \frac{Q_{t\text{th}}}{a_1}, v_2 = \frac{Q_{t\text{th}}}{a_2}$$

$$= \frac{Q_{t\text{th}}^2}{2g} \left(\frac{1}{a_2^2} - \frac{1}{a_1^2} \right)$$

$$Q_{t\text{th}} = \frac{a_1 a_2 \sqrt{2gh}}{a_1^2 - a_2^2}$$

$$Q = C_d Q_{t\text{th}}$$

$$= \frac{C_d a_1 a_2 \sqrt{2gh}}{a_1^2 - a_2^2}$$

$$= C_d$$

$$\therefore C = \frac{a_2 \sqrt{2gh}}{a_1^2 - a_2^2}$$

$$Q_{\text{actual}} = C_d C \sqrt{h}$$

C_d = Co-efficient of discharge < 1

ORIFICE METER

An orifice meter is a simple device for measuring the discharge through pipes. Orifice meter also works on the same principle as that of venturimeter i.e by reducing cross-sectional area of the flow passage, a pressure difference between the two sections is developed and the measurement of the pressure difference enables the determination of the discharge through the pipe. Orifice meter is a cheaper arrangement and requires smaller length and can be used where space is limited.

An orifice meter consists of a flat circular plate with a circular hole called orifice, which is concentric with the pipe axis. The thickness of the plate t is less than or equal to 0.05

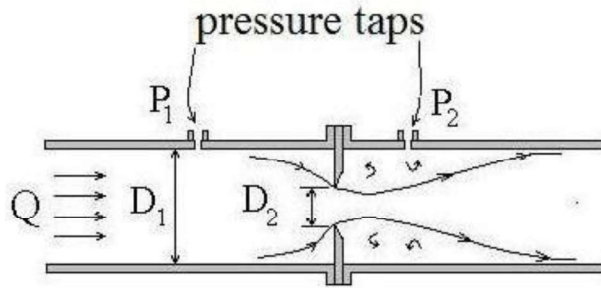

times the diameter of pipe. From the upstream face of the plate the edge of the orifice is made flat for a thickness 0.02 times the diameter of pipe and the remaining thickness the plate is beveled with the bevel angle 45° . The diameter of the orifice is kept at 0.5 times the diameter of pipe. Two pressure taps are provided one at section 1 on upstream side of the orifice plate and other at section 2 on the downstream side of the orifice plate. The upstream tap is located at a distance of 0.9 to 1.1 times the pipe diameter from the orifice plate. The position of downstream pressure tap, however depends on the ratio of the orifice diameter and the pipe diameter. Since the orifice diameter is less than pipe diameter as the fluid flows through the orifice, the flowing stream converges, which results in the acceleration of the flowing fluid in accordance with the consideration of continuity. The effect of convergence of flowing stream extends up to a certain distance upstream from the orifice plate and therefore the pressure tap on the upstream side is provided away from the orifice plate at a section where this effect is non-existent. However on the downstream side the pressure tap is provided quite close to the orifice plate at a section where the converging jet of fluid has the smallest cross-sectional area (which is known as vena-contracta) resulting in the max. velocity of flow and consequently the min. pressure at this section. Therefore a max. Pressure difference exists between the section 1 and 2, which is measured by connecting a differential manometer between the pressure taps at these sections or connecting separate pressure gauges. The jet of fluid coming out of the orifice gradually expands from the vena-contracta to again fill the pipe. In case of an orifice meter an abrupt change in the cross-sectional area of the flow passage is provided and there being no gradual change in the cross-sectional area of flow passage as in the case of venturimeter, there is a greater loss of energy in an orifice meter.

Let p_1, p_2 and v_1, v_2 be the pressures and velocities at sections 1 and 2 respectively. Then for an incompressible fluid, applying Bernoulli's equation between section 1 and 2 and neglecting losses, we have

$$\begin{aligned}
 \frac{p_1}{\rho} + \frac{v_1^2}{2g} + z &= \frac{p_2}{\rho} + \frac{v_2^2}{2g} + z \\
 \text{Or } \frac{p_1}{\rho} + z - \frac{v_1^2}{2g} &= \frac{p_2}{\rho} + z - \frac{v_2^2}{2g} \\
 \frac{p_1}{\rho} - \frac{v_1^2}{2g} &= \frac{p_2}{\rho} - \frac{v_2^2}{2g} \quad \text{--- (1)}
 \end{aligned}$$

Where h is the difference between piezo metric heads at sections 1 and 2. However if the orifice meter is connected in a horizontal pipe, then $z_1 = z_2$, in which case h will represent the pressure head difference between sections 1 and 2. From equation (1) we have

$$v_2 = \sqrt{2g h + v_1^2} \quad (2)$$

In deriving the above expression losses have not been considered, this expression gives the theoretical velocity of flow at section 2. To obtain actual velocity, it must be multiplied by a factor C_v , called co-efficient of velocity, which is defined as the ratio between the actual velocity and theoretical velocity. Thus actual velocity of flow at section 2 is obtained as

$$v_2 = C_v \sqrt{2g h + v_1^2} \quad (3)$$

Further if a_1 and a_2 are the cross-sectional areas of pipe at section 1 and 2,

$$\text{By continuity equation } Q = a_1 v_1 = a_2 v_2 \quad (4)$$

The area of jet a_2 at section 2 (i.e. at vena-contracta) may be related to the area of orifice a_0 by the following expression

$a_2 = C_c a_0$ where C_c is known as co-efficient of contraction, which is defined as the ratio between the area of the jet at vena-contracta and the area of orifice. Thus introducing the value of a_2 in equation (4), we get

$$v_1 = v_2 \frac{C_c a_0}{a_1} \quad \text{By substituting this value of } v_1 \text{ in equation (3), we get}$$

$$v_2 = C_v \sqrt{2g h + \frac{C_c^2 a_0^2}{a_1^2} v_2^2}$$

$$\text{Solving for } v_2, \text{ we get } v_2 = \frac{2g h}{1 - C_v^2 C_c^2 \frac{a_0^2}{a_1^2}}$$

$$\text{Now } Q = a_2 v_2 = C_c a_0 v_2 \text{ and } C_c C_v = C_d$$

$$Q = \frac{C_c a_0 \sqrt{2g h}}{1 - C_c^2 \frac{a_0^2}{a_1^2}} = \frac{C_d a_0 \sqrt{2g h}}{1 - C_d^2 \frac{a_0^2}{a_1^2}}$$

Where C_d is the co-efficient of discharge of the orifice.

Simplifying the above expression for the discharge through the orifice meter by using a co-efficient C expressed as

$$C = \frac{C_d \sqrt{1 - \frac{a_0^2}{a_1^2}}}{1 - C_d^2 \frac{a_0^2}{a_1^2}}$$

So that

$$Q = \frac{C a_0 \sqrt{2g h}}{1 - \frac{a_0^2}{a_1^2}} = C \frac{a_0 \sqrt{2g h}}{1 - \frac{a_0^2}{a_1^2}}$$

$$Q = C \frac{a_0 \sqrt{2g h}}{1 - \frac{a_0^2}{a_1^2}}$$

This gives the discharge through an orifice meter and is similar to the discharge through venturimeter. The co-efficient C may be considered as the co-efficient of discharge of an orifice meter. The co-efficient of discharge for an orifice meter is smaller than that for a venturimeter. This is because there are no gradual converging and diverging flow passages as in the case of venturimeter, which results in a greater loss of energy and consequent reduction of the co-efficient of discharge for an orifice meter.

PROBLEMS ON FLOW THROUGH PIPES

1. At a sudden enlargement of a water main from 240mm to 480mm diameter, the hydraulic gradient rises by 10mm. Estimate the rate of flow.

Given: Dia. of smaller pipe $D_1 = 240\text{mm} = 0.24\text{m}$

$$\text{Area } A_1 = \frac{\pi}{4} D_1^2 = \frac{\pi}{4} (0.24)^2$$

Dia. of larger pipe $D_2 = 480\text{mm} = 0.48\text{m}$

$$\text{Area } A_2 = \frac{\pi}{4} D_2^2 = \frac{\pi}{4} (0.48)^2$$

$$\text{Rise of hydraulic gradient i.e. } Z_2 + \frac{P_2}{\rho g} - Z_1 + \frac{P_1}{\rho g} = 10\text{mm} = \frac{10}{1000} \text{m} = \frac{1}{100} \text{m}$$

Let the rate of flow = Q

Applying Bernoulli's equation to both sections i.e smaller and larger sections

$$\frac{P_1}{\rho g} + \frac{V_1^2}{2g} + Z_1 = \frac{P_2}{\rho g} + \frac{V_2^2}{2g} + Z_2 + \text{Head loss due to enlargement} \quad (1)$$

$$\text{But head loss due to enlargement, } = \frac{V_1 - V_2}{2g} \quad (2)$$

From continuity equation, we have $A_1 V_1 = A_2 V_2$ $V_1 = \frac{A_2 V_2}{A_1}$

$$V_1 = \frac{\frac{\pi}{4} D_2^2 V_2}{\frac{\pi}{4} D_1^2} = \frac{D_2^2}{D_1^2} \times V_2 = \frac{0.48^2}{0.24^2} V_2 = 2^2 V_2 = 4V_2$$

Substituting this value in equation (2), we get

$$\frac{V_1 - V_2}{2g} = \frac{4V_2 - V_2}{2g} = \frac{3V_2}{2g} = \frac{9V_2^2}{2g}$$

Now substituting the value of h_e and V_1 in equation (1)

$$\frac{P_1}{\rho g} + \frac{4V_2^2}{2g} + Z_1 = \frac{P_2}{\rho g} + \frac{V_2^2}{2g} + Z_2 + \frac{9V_2^2}{2g}$$

$$\frac{16V_2^2}{2g} - \frac{V_2^2}{2g} - \frac{9V_2^2}{2g} = \frac{P_2}{\rho g} + Z_2 - \frac{P_1}{\rho g} + Z_1$$

$$\text{But Hydraulic gradient rise} = \frac{P_2}{\rho g} + Z_2 - \frac{P_1}{\rho g} + Z_1 = \frac{1}{100} \text{m}$$

$$\frac{6V_2^2}{2g} = \frac{1}{100} \text{m} \quad V_2 = \frac{2 \times 9.81}{6 \times 100} = 0.1808 = 0.181 \text{m/sec}$$

$$\text{Discharge } Q = A_2 V_2 = \frac{\pi}{4} D_2^2 V_2$$

$$= \frac{\pi}{4} (0.48)^2 \times 0.181 = 0.03275 \text{m}^3/\text{sec}$$

$$= \underline{\underline{32.75 \text{Lts/sec}}}$$

2. A 150mm dia. pipe reduces in dia. abruptly to 100mm dia. If the pipe carries water at 30lts/sec, calculate the pressure loss across the contraction. Take co-efficient of contraction as 0.6

Given: Dia. of larger pipe $D_1 = 150\text{mm} = 0.15\text{m}$

$$\text{Area of larger pipe } A_1 = \frac{\pi}{4}(0.15)^2 = 0.01767\text{m}^2$$

Dia. of smaller pipe $D_2 = 100\text{mm} = 0.10\text{m}$

$$\text{Area of smaller pipe } A_2 = \frac{\pi}{4}(0.10)^2 = 0.007854\text{m}^2$$

Discharge $Q = 30 \text{ lts/sec} = 0.03\text{m}^3/\text{sec}$

Co-efficient of contraction $C_c = 0.6$

From continuity equation, we have $Q = A_1 V_1 = A_2 V_2$

$$V_1 = \frac{Q}{A_1} = \frac{0.03}{0.01767} = 1.697 \text{ m/sec}$$

$$V_2 = \frac{Q}{A_2} = \frac{0.03}{0.007854} = 3.82 \text{ m/sec}$$

Applying Bernoulli's equation before and after contraction

$$\frac{P_1}{\rho g} + \frac{V_1^2}{2g} + Z_1 = \frac{P_2}{\rho g} + \frac{V_2^2}{2g} + Z_2 + h_c \quad \text{-----(1)}$$

But $Z_1 = Z_2$ and h_c the head loss due to contraction is given by the equation

$$= \frac{V_2^2}{2g} \left(\frac{1}{C_c} - 1 \right)^2 = \frac{3.82^2}{2 \times 9.81} \left(\frac{1}{0.6} - 1 \right)^2 = 0.33$$

Substituting these values in equation (1), we get

$$\frac{P_1}{\rho g} + \frac{1.697^2}{2 \times 9.81} = \frac{P_2}{\rho g} + \frac{3.82^2}{2 \times 9.81} + 0.33$$

$$\frac{P_1}{\rho g} + 0.1467 = \frac{P_2}{\rho g} + 0.7438 + 0.33$$

$$\frac{P_1}{\rho g} - \frac{P_2}{\rho g} = 0.7438 + 0.33 - 0.1467 = 0.9271 \text{ m of Water}$$

$$P_1 - P_2 = \rho g \times 0.9271 = 1000 \times 9.81 \times 0.9271 = 0.909 \times 10^4 \text{ N/m}^2$$

$$= 0.909 \text{ N/cm}^2$$

Pressure loss across contraction = $P_1 - P_2 = 0.909\text{N/cm}^2$

3. Water is flowing through a horizontal pipe of diameter 200mm at a velocity of 3m/sec. A circular solid plate of diameter 150mm is placed in the pipe to obstruct the flow. Find the loss of head due to obstruction in the pipe, if $C_C = 0.62$.

Given: Diameter of pipe $D = 200\text{mm} = 0.2\text{m}$

Velocity $V = 3\text{m/sec}$

$$\text{Area of pipe } A = \frac{\pi D^2}{4} = \frac{\pi (0.2)^2}{4} = 0.03141\text{m}^2$$

Diameter of obstruction $d = 150\text{mm} = 0.15\text{m}$

$$\text{Area of obstruction } a = \frac{\pi (0.15)^2}{4} = 0.01767\text{m}^2$$

$$C_C = 0.62$$

$$\begin{aligned} \text{The head loss due to obstruction} &= \frac{v^2}{2g} \left(\frac{A}{A-a} - 1 \right)^2 \\ &= \frac{3 \times 3}{2 \times 9.81} \left(\frac{0.03141}{0.62 \times 0.03141 - 0.01767} - 1 \right)^2 \\ &= \frac{9}{19.62} [3.687 - 1]^2 \\ &= \underline{\underline{3.311\text{m}}} \end{aligned}$$

Problems on Pitot tube

1. A pitot tube is placed in the centre of a 300mm pipe line has one end pointing upstream and other perpendicular to it. The mean velocity in the pipe is 0.80 of the central velocity. Find the discharge through the pipe, if the pressure difference between the two orifices is 60mm of water. Co-efficient of Pitot tube $C_v = 0.98$

Given: Diameter of pipe = 300mm = 0.3m

Difference of pressure head $h = 60\text{mm of water} = 0.06\text{m of water}$

Mean velocity $V = 0.80 \times \text{central velocity}$

$$\text{Central velocity} = C_v \sqrt{2g h} = 0.98 \times \sqrt{2 \times 9.81 \times 0.06} = 1.063 \text{ m/sec}$$

$$\text{Mean velocity} = 0.8 \times 1.063 = 0.8504\text{m/sec}$$

Discharge $Q = \text{Area of pipe} \times \text{Mean velocity} = A \times V$

$$= \frac{\pi (0.3)^2}{4} \times 0.8504$$

$$= \underline{\underline{0.06\text{m}^3/\text{sec}}}$$

2. Find the velocity of flow of an oil through a pipe, when the difference of mercury level in a differential U-tube manometer connected to the two tappings of the pitot tube is 100mm. Co-efficient of pitot tube $C = 0.98$ and sp.gr.of oil = 0.8.

Given: Difference of mercury level $x = 100\text{mm} = 0.1\text{m}$

Sp.gr. of oil = 0.8, $C_v = 0.98$

$$\begin{aligned} \text{Difference of pressure head } \left[\frac{x}{S} \right] &= x \frac{S_m}{S} - 1 = 0.1 \frac{13.6}{0.8} - 1 \\ &= 1.6 \text{ m of oil} \end{aligned}$$

$$\text{Velocity of flow} = C_v \sqrt{2 \times g \times \left[\frac{x}{S} \right]} = 0.98 \sqrt{2 \times 9.81 \times 1.6} = 5.49\text{m/sec}$$

$$= 5.49\text{m/sec}$$

3. A pitot tube is used to measure the velocity of water in a pipe. The stag nature pressure head is 6m and static pressure head is 5m. Calculate the velocity of flow. Co-efficient of pitot tube is 0.98.

Given: Stag nature pressure head $h_s = 6\text{m}$

Static pressure head $h_t = 5\text{m}$

$$h = h_s - h_t = 6 - 5 = 1\text{m}$$

$$\begin{aligned} \text{Velocity of flow } V &= C_v \sqrt{2 \times g \times h} \\ &= 0.98 \sqrt{2 \times 9.81 \times 1} \end{aligned}$$

$$= 4.34 \text{ m/sec}$$

4. A submarine moves horizontally in a sea and has its axis 15m below the surface of the water. A pitot tube is properly placed just in front of the submarine and along its axis is connected to the two limbs of a U- tube containing mercury. The difference of mercury level is found to be 170mm. Find the speed of the sub-marine. Specific gravity of mercury is 13.6 and sea water is 1.026 with respect to fresh water.

Given: Difference of mercury level = 170mm = 0.17m

Specific gravity of mercury $S_m = 13.6$,

Specific gravity of sea water $S_o = 1.026$

$$\left[\frac{x}{S} \right] = x \frac{S_m}{S} - 1 = 0.17 \frac{13.6}{1.026} - 1 = 3.0834$$

$$V = \sqrt{2 g \left[\frac{x}{S} \right]} = \sqrt{2 \times 9.81 \times 3.0834}$$

$$= 6.393 \text{ m/sec}$$

$$= \frac{6.393 \times 60 \times 60}{1000}$$

$$= 23.01 \text{ km / hr}$$

5. A pitot tube is inserted in a pipe of 300mm diameter. The static pressure in the pipe is 100mm of mercury (Vacuum). The stagnation pressure at the centre of the pipe is recorded by Pitot tube is 0.981N/cm^2 . Calculate the rate of flow of water through the pipe. The mean velocity of flow is 0.85 times the central velocity $C_v = 0.98$

Given: Diameter of pipe $d = 0.3\text{m}$

$$\text{Area of pipe } a = \frac{\pi}{4}(0.3)^2 = 0.07068\text{m}^2$$

$$\text{Static pressure head} = 100\text{mm of mercury} = \frac{100}{1000} \times 13.6 = 1.36\text{m of water}$$

$$\text{Stag nature pressure head} = \frac{0.981 \times 10^4}{1000} \times 9.81 = 1$$

$h = \text{Stagnation pressure head} -$

$$\text{static pressure head} = 1 - (-1.36) = 2.36\text{m}$$

$$\text{Velocity at centre} = C_v \sqrt{2g h} = 0.98 \sqrt{2 \times 9.81 \times 2.36}$$

$$= 9.81 \times 2.36 = 6.668\text{m/sec}$$

$$\text{Mean velocity } V = 0.85 \times 6.668 = 5.6678\text{m/sec}$$

$$\begin{aligned} \text{Rate of flow of water} &= V \times \text{Area of pipe} \\ &= 5.6678 \times 0.07068 \end{aligned}$$

$$= \mathbf{0.4006\text{m}^3/\text{sec}}$$

UNIT-4

BASICS OF TURBO MACHINERY

HYDRO-DYNAMIC FORCE OF JETS:

The liquid comes out in the form of a jet from the outlet of a nozzle, the liquid is flowing under pressure. If some plate, which may be fixed or moving, is placed in the path of the jet, a force is exerted by the jet on the plate. This force is obtained by Newton's second law of motion or from Impulse – Momentum equation.

$$F = ma \quad \text{or} \quad F \times dt = d \, mv$$

Thus the impact of jet means, the force exerted by the jet on a plate, which may be stationary or moving.

The following cases of impact of jet i.e. the force exerted by the jet on a plate will be considered.

1) Force exerted by the jet on a stationary plate, when

- a) Plate is vertical to the jet.
- b) Plate is inclined to the jet and
- c) Plate is curved

2) Force exerted by the jet on a moving plate, when

- a) Plate is vertical to the jet.
- b) Plate is inclined to the jet.
- c) Plate is curved.

a) FORCE EXERTED BY THE JET ON A STATIONARY VERTICAL PLATE:

Consider a jet of water coming out from the nozzle, strikes a flat vertical plate.

Let V = Velocity of jet.

d = Diameter of jet.

a = Area of cross-section of jet. $= \frac{\pi d^2}{4}$

The jet of water after striking the plate will move along the plate. But the plate is at right angles to the jet. Hence the jet after striking will be deflected through 90° .

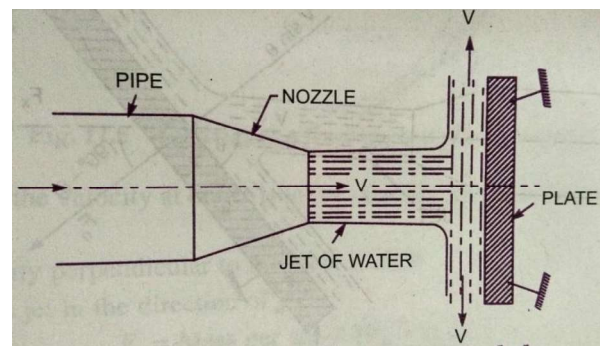

Hence the component of the velocity of the jet, in the direction of jet, after striking will be zero.

The force exerted by the jet on the plate in the direction of jet,

$F_x = \text{Rate of change of momentum in the direction of force.}$

$$= \frac{\text{Initial momentum} - \text{Final momentum}}{\text{Time}}$$

$$= \frac{\text{Mass} \times \text{Initial velocity} - \text{Mass} \times \text{Final velocity}}{\text{Time}}$$

$$= \frac{\text{Mass}}{\text{Time}} (\text{Initial velocity} - \text{Final velocity})$$

$$= \text{Mass/sec} \times (\text{Velocity of jet before striking} - \text{Final velocity of jet after striking})$$

$$= \rho a V (V - 0)$$

$$F_x = \rho a V^2$$

For deriving the above equation, we have taken initial velocity minus final velocity and not final velocity minus initial velocity. If the force exerted on the jet is to be calculated, then final velocity minus initial velocity is to be taken. But if the force exerted by the jet on the plate is to be calculated, then initial velocity minus final velocity is to be taken.

b) Force exerted by a jet on a stationary inclined Flat plate:

Let a jet of water coming out from the nozzle, strikes an inclined flat plate.

$V = \text{Velocity of jet in the direction of X}$

$\theta = \text{Angle between the jet and plate.}$

$a = \text{Area of cross-section of jet.}$

Mass of water per second striking the plate $= \rho a v$

If the plate is smooth and there is no loss energy due to impact of the jet, the jet will move over the plate after striking with a velocity equal to initial velocity.

with a velocity V . Let us find the force exerted by the jet on the plate in the direction normal to the plate. Let this force is represented by F_n .

Then $F_n = \text{Mass of jet striking per second}$

$\times (\text{Initial velocity of jet before striking in the direction of n}$

$- \text{Final velocity of jet after striking in the direction of n})$

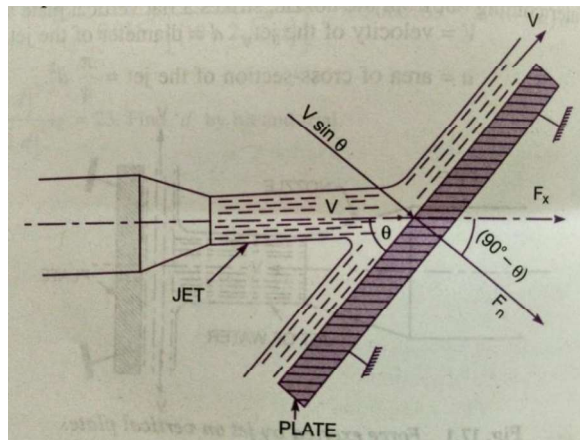

of

i.e.

$$= \rho a V (V \sin \theta - 0) = \rho a V^2 \sin \theta \text{-----(1)}$$

This force can be resolved in two components, one in the direction of the jet and the other perpendicular to the direction of flow.

Then we have $F_x =$ Component of F_n in the direction of flow.

$$F_x = F_n \cos 90 - \theta = F_n \sin \theta = \rho a V^2 \sin \theta \times \sin \theta$$

$$F_x = \rho a V^2 \sin^2 \theta \text{-----(1)}$$

And $F_y =$ Component of F_n in the direction perpendicular to the flow.

$$F_y = F_n \sin 90 - \theta = F_n \cos \theta = \rho a V^2 \sin \theta \times \cos \theta$$

$$F_y = \rho a V^2 \sin \theta \cos \theta \text{-----(2)}$$

c) Force exerted by a jet on a stationary Curved plate:

i) Jet strikes the curved plate at the centre:

The jet after striking the plate comes out with same velocity, if the plate is smooth and there is no loss of energy due to impact of the jet, in the tangential direction of the curved plate. The velocity at the out let of the plate can be resolved in to two components, one in the direction of the jet and other perpendicular to the direction of jet.

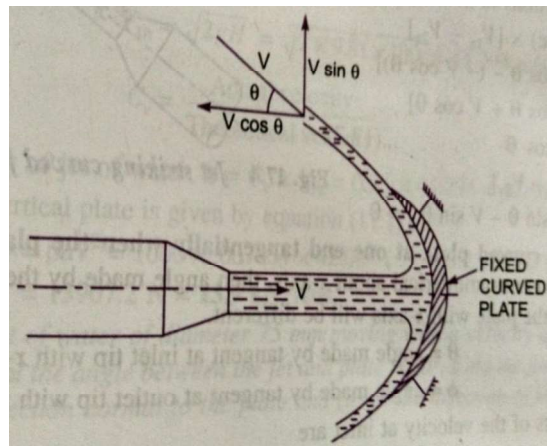

Component of velocity in the direction of jet = $-V \cos \theta$

(-ve sign is taken as the velocity at out let is in the opposite direction of the jet of water coming out from nozzle.)

Component of velocity perpendicular to the jet = $V \sin \theta$

Force exerted by the jet in the direction of the jet

$$F_x = \text{Mass per sec} (V_{1x} - V_{2x})$$

Where $V_{1x} =$ Initial velocity in the direction of jet = V

$V_{2x} =$ Final velocity in the direction of jet = $-V \cos \theta$

$$F_x = \rho a V [V - (-V \cos \theta)] = \rho a V [V + V \cos \theta] = \rho a V^2 (1 + \cos \theta) \text{-----(1)}$$

Similarly $F_y = \text{Mass per second} (V_{1y} - V_{2y})$

Where $V_{1y} =$ Initial velocity in the direction of $y = 0$

$V_{2y} =$ Final velocity in the direction of $y = V \sin \theta$

$$F_y = \rho a V [0 - V \sin \theta] = -\rho a V^2 \sin \theta \text{-----(2)}$$

-ve sign means the force is acting in the downward direction.

In this case the angle of deflection of jet = $180^\circ - \theta$

ii) Jet strikes the curved plate at one end tangentially when the plate is symmetrical:

Let the jet strikes the curved fixed plate at one end tangentially. Let the curved plate is symmetrical about x -axis. Then the angle made by the tangents at the two ends of the plate will be same.

Let V = Velocity of jet of water.
 θ = Angle made by the jet with x -axis at the inlet tip of the curved plate.

If the plate is smooth and loss of energy due to impact is zero, then the velocity of water at the outlet tip of the curved plate will be equal to V . The force exerted by the jet of water in the direction of x and y are

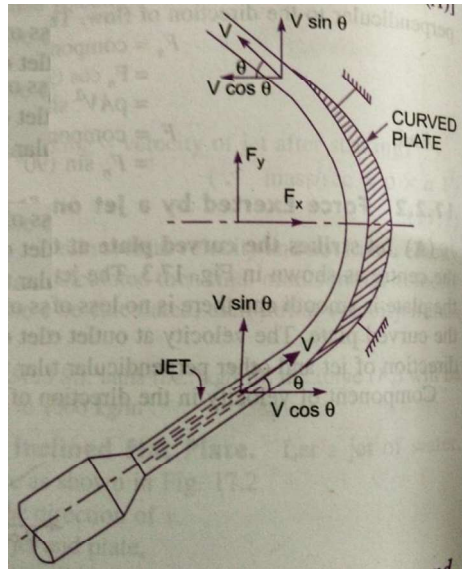

$$F_x = (\text{mass/sec}) \times (V_{1x} - V_{2x})$$

$$= \rho a V [V \cos \theta - (-V \cos \theta)]$$

$$= 2 \rho a V^2 \cos \theta$$

$$F_y = \rho a V (V_{1y} - V_{2y}) = \rho a V [V \sin \theta - V \sin \theta] = 0$$

iii) Jet strikes the curved plate at one end tangentially when the plate is unsymmetrical:

When the curved plate is unsymmetrical about x - axis, then the angles made by tangents drawn at inlet and outlet tips of the plate with x - axis will be different.

Let θ = Angle made by tangent at the inlet tip with x -axis.

ϕ = Angle made by tangent at the outlet tip with x -axis

The two components of velocity at inlet are

$$V_{1x} = V \cos \theta \text{ and } V_{1y} = V \sin \theta$$

The two components of velocity at outlet are

$$V_{2x} = -V \cos \phi \text{ and } V_{2y} = V \sin \phi$$

The forces exerted by the jet of water in the directions of x and y are:

$$F_x = \rho a V (V_{1x} - V_{2x}) = \rho a V (V \cos \theta + V \cos \phi)$$

$$= \rho a V^2 (\cos \theta + \cos \phi)$$

$$F_y = \rho a V (V_{1y} - V_{2y}) = \rho a V [V \sin \theta - V \sin \phi] = \rho a V^2 (\sin \theta - \sin \phi)$$

FORCE EXERTED BY A JET ON MOVING PLATES

The following cases of the moving plates will be considered:

- Flat vertical plate moving in the direction of jet and away from the jet.
- Inclined plate moving in the direction of jet and
- Curved plate moving in the direction of jet or in the horizontal direction.

a) Force on flat vertical plate moving in the direction of jet:

Let a jet of water striking a flat vertical plate moving with a uniform velocity away from the jet.

Let V = Velocity of jet.
 a = Area of cross-section of jet.
 u = Velocity of flat plate.

In this case, the jet does not strike the plate with a velocity v , but it strikes with a relative velocity, which is equal to the absolute velocity of jet of water minus velocity of the plate.

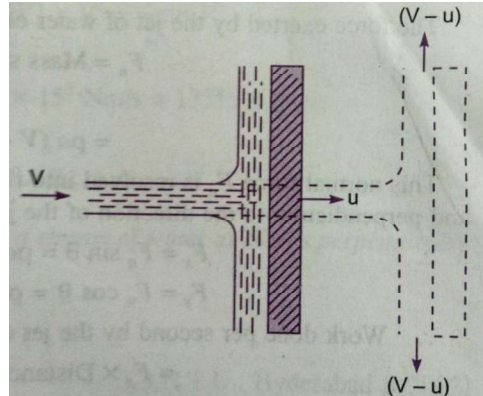

Hence relative velocity of the jet with respect to plate = $V - u$

Mass of water striking the plate per second

$$= \rho \times \text{Area of jet} \times \text{velocity with which jet strikes the plate}$$

$$= \rho a (V - u)$$

∴ Force exerted by the jet on the moving in the direction of the plate

F_x = mass of water striking per second \times (Initial velocity with which water strikes – Final velocity)

$$= \rho a (V - u)[(V - u) - 0] = \rho a (V - u)^2 \text{----- (1)}$$

Since final velocity in the direction of jet is zero.

In this, case the work will be done by the jet on the plate, as the plate is moving. For stationary plates, the work done is zero.

∴ The work done per second by the jet on the plate

$$= \text{Force} \times \frac{\text{Distance in the direction of force}}{\text{Time}}$$

$$= F_x \times u = \rho a (V - u)^2 \times u \text{----- (2)}$$

In the above equation (2), if the value of ρ for water is taken in S.I units (i.e. 1000 kg/m^3) the work done will be in N m/s. The term $\frac{\text{Nm}}{\text{s}}$ is equal to Watt (W).

b) Force on inclined plate moving in the direction of jet:

Let a jet of water strikes an inclined plate, which is moving with a uniform velocity in the direction of jet.

Let V = Absolute velocity of water.

u = Velocity of plate in the direction of jet.

a = Cross-sectional area of jet

θ = Angle between jet and plate.

Relative velocity of jet of water = $V - u$

The velocity with which jet strikes = $V - u$

Mass of water striking per second = $\rho a (V - u)$

If the plate is smooth and loss of energy due to impact of the jet is assumed zero, the jet of water will leave the inclined plate with a velocity equal to $V - u$.

The force exerted by the jet of water on the plate in the direction normal to the plate is given as

F_n = Mass striking per sec x (Initial velocity in the normal direction with which jet strikes – final velocity)

$$= \rho a (V - u) [(V - u) \sin\theta - 0]$$

$$= \rho a (V - u)^2 \sin\theta$$

This normal force F_n is resolved in to two components, namely F_x and F_y in the direction of jet and perpendicular to the direction of jet respectively.

$$F_x = F_n \sin\theta = \rho a (V - u)^2 \sin^2\theta$$

$$F_y = F_n \cos\theta = \rho a (V - u)^2 \sin\theta \cos\theta$$

Work done per second by the jet on the plate

$$= F_x \times \text{Distance per second in the direction of } x$$

$$= F_x \times u = \rho a (V - u)^2 \sin^2\theta \times u$$

$$= \rho a (V - u)^2 u \sin^2\theta \text{ N m/sec}$$

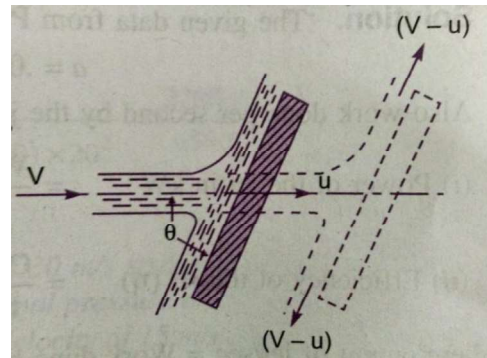

c) Force on the curved plate when the plate is moving in the direction of jet:

Let a jet of water strikes a curved plate at the centre of the plate, which is moving with a uniform velocity in the direction of jet.

Let V = absolute velocity of jet.

a = area of jet.

u = Velocity of plate in the direction of jet.

Relative velocity of jet of water or the velocity with which jet strikes the curved plate = $V - u$

If the plate is smooth and the loss of energy due to impact of jet is zero, then the velocity with which the

jet will be leaving the curved vane = $(V - u)$

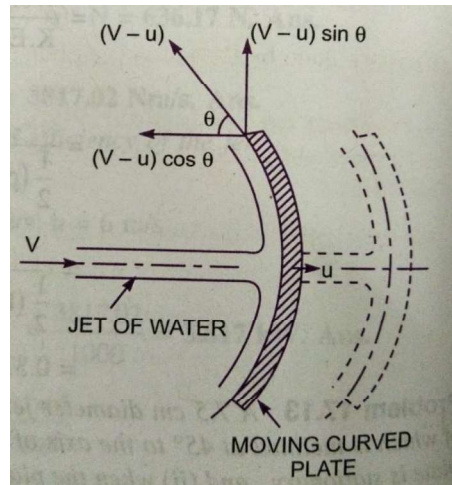

This velocity can be resolved into two components, one in the direction of jet and the other perpendicular to the direction of jet.

Component of the velocity in the direction of jet = $-(V - u) \cos \theta$

(-ve sign is taken as at the out let, the component is in the opposite direction of the jet).

Component of velocity in the direction perpendicular to the direction of jet = $(V - u) \sin \theta$

Mass of water striking the plate = $\rho a \times$ velocity with which jet strikes the plate.

$$= \rho a (V - u)$$

\therefore Force exerted by the jet of water on the curved plate in the direction of jet F_x

$$F_x = \text{Mass striking per sec [Initial velocity with which jet strikes the plate in the direction of jet - Final velocity]}$$

$$= \rho a V - u V - u - - V - u \cos \theta$$

$$= \rho - ^2 1 + \cos \theta \text{_____} (1)$$

Work done by the jet on the plate per second

$$= F_x \times \text{Distance travelled per second in the direction of } x$$

$$= F_x \times u = \rho a V - u ^2 1 + \cos \theta \times u$$

$$= \rho a V - u ^2 \times u 1 + \cos \theta$$

d) Force exerted by a jet of water on an un-symmetrical moving Curved plate when Jet strikes tangentially at one of the tips:

Let a jet of water striking a moving curved plate tangentially, at one of its tips.

As the jet strikes tangentially, the loss of energy due to impact of the jet will be zero. In this case as plate is moving, the velocity with which the jet of water strikes is equal to the relative velocity of jet with respect to the plate. Also as the plate is moving in different direction of the jet, the relative velocity at inlet will be equal to the vector difference of velocity of jet and velocity of the plate at inlet.

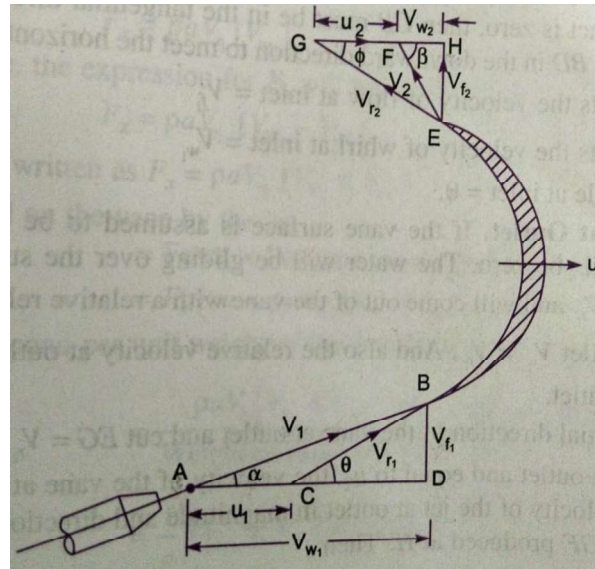

Let V_1 = Velocity of jet at inlet.

u_1 = Velocity of the plate at inlet.

V_{r1} = Relative velocity of jet and plate at inlet.

α = Angle between the direction of jet and direction of moving plate.

θ = Angle made by relative velocity (V_{r2}) with direction of motion at inlet.

(Vane angle at inlet)

V_{w1} and V_{f1} = The components of velocity of the jet V_1 , in the direction of motion and Perpendicular to the direction of motion respectively.

V_{w1} = Velocity of whirl at inlet.

V_{f1} = Velocity of flow at inlet.

V_2 = Velocity of jet at the outlet of the vane.

u_2 = Velocity of vane at outlet.

V_{r2} = Relative velocity of jet w.r.t the vane at the outlet.

= Angle made by the velocity V_2 with direction of motion of vane at outlet.

= Angle made by the relative velocity V_{r2} with the direction of motion of the Vane at outlet.

V_{w2} and V_{f2} = Components of velocity V_2 in the direction of motion of vane and Perpendicular to the direction of motion of vane at outlet.

V_{w2} = Velocity of whirl at outlet.

V_{f2} = Velocity of flow at outlet.

The triangles ABD and EGH are called velocity triangles at inlet and outlet.

Velocity triangle at inlet: Take any point A and draw a line $AB = V_1$ in magnitude and direction which means line AB makes an angle α with the horizontal line AD. Next draw a line $AC = u_1$ in magnitude. Join C to B. Then CB represents the relative velocity of the jet at inlet. If the loss of energy at inlet due to impact is zero, then CB must be in the tangential direction to the vane at inlet. From B draw a vertical line BD in the downward direction to meet the horizontal line AC produced at D.

Then $BD =$ Represents the velocity of flow at inlet $= V_{f1}$

$AD =$ Represents the velocity of whirl at inlet $= V_{w1}$

$\angle BCD =$ Vane angle at inlet $= \theta$

Velocity triangle at outlet: If the vane surface is assumed to be very smooth, the loss of energy due to friction will be zero. The water will be gliding over the surface of the vane with a relative velocity V_{r1} and will come out of the vane with a relative velocity V_{r2} . This means that the relative velocity at outlet $V_{r2} = V_{r1}$. The relative velocity at outlet should be in tangential direction to the vane at outlet.

Draw EG in the tangential direction of the vane at outlet and cut $EG = V_{r2}$. From G, draw a line GF in the direction of vane at outlet and equal to u_2 , the velocity of vane at outlet. Join EF. Then EF represents the absolute velocity of the jet at outlet in magnitude and direction. From E draw a vertical line EH to meet the line GF produced at H.

Then, $EH =$ Velocity of flow at outlet. $= V_{f2}$.

$FH =$ Velocity of whirl at outlet $= V_{w2}$

$\phi =$ Angle of vane at outlet

$\beta =$ Angle made by V_2 with the direction of motion of vane at outlet.

If vane is smooth and is having velocity in the direction of motion at inlet and outlet equal, then we have

$u_1 = u_2 = u =$ velocity of vane in the direction of motion and

$$V_{r1} = V_{r2}$$

Now mass of water striking the vane per second $\rho a V_{r1}$ (1)

Where $a =$ area of jet of water, $V_{r1} =$ Relative velocity at inlet.

\therefore Force exerted by the jet in the direction of motion

$F_x =$ Mass of water striking per second \times [Initial velocity with which jet strikes in the direction of motion – Final velocity of jet in the direction of motion]----- (2)

But initial velocity with which jet strikes the vane = V_{r1}

The component of this velocity in the direction of motion = $V_{r1} \cos \theta = V_{w1} - u_1$ similarly, the component of relative velocity at the outlet in the direction of motion

$$= V_{r2} \cos \phi = -u_2 + V_{w2}$$

Ve sign is taken as the component of the relative velocity V_{r2} in the direction of motion is in the opposite direction

Substituting the equation (1) and all the above values of the velocities in equation (2), we get

$$\begin{aligned} &= \rho a V_{r1} (V_{w1} - u_1) - (-u_2 + V_{w2}) = \rho a V_{r1} (V_{w1} - u_1 + u_2 - V_{w2}) \\ &= \rho a V_{r1} (V_{w1} + V_{w2}) \quad \text{since } u_1 = u_2 \end{aligned} \quad (3)$$

The equation (3) is true only when angle β is an acute angle. If $\beta = 90^\circ$, then $V_{w2} = 0$

Then equation (3) becomes as $F_x = \rho a V_{r1} V_{w1}$

If β is an obtuse angle, then the expression for F_x will become

$$= \rho a V_{r1} (-V_{w2})$$

Thus in general, F_x is written as $F_x = \rho a V_{r1} \pm V_{w2}$

Work done per second on the vane by the jet

$$\begin{aligned} &= \text{Force} \times \text{distance per second in the direction of force} \\ &= F \times u = \rho a V_{r1} (\pm V_{w2}) \times u \end{aligned} \quad (5)$$

\therefore Work done per second per unit weight of fluid striking per second

$$\begin{aligned} &= \frac{\rho a V_{r1} (\pm V_{w2}) \times u}{\text{weight of fluid striking/s}} \frac{Nm/s}{N/s} = \frac{\rho a V_{r1} (\pm V_{w2}) \times u}{g \times \rho a V_{r1}} = Nm/N \\ &= \frac{1}{g} (\pm V_{w1} \pm V_{w2}) \times u \quad (6) \end{aligned}$$

Work done/second per unit mass of fluid striking per second

$$\begin{aligned} &= \frac{\rho a V_{r1} (\pm V_{w2}) \times u}{\text{weight of fluid striking/s}} \frac{Nm/s}{kg} = \frac{\rho a V_{r1} (\pm V_{w2}) \times u}{\rho a V_{r1}} \\ &= \pm V_{w2} \times u \quad (7) \end{aligned}$$

Efficiency of jet: The work done by the jet on the vane given by equation (5) is the output of the jet whereas the initial kinetic energy of the jet is the input. Hence the efficiency of jet is expressed as

$$\begin{aligned} \text{Efficiency } \eta &= \frac{\text{Out put}}{\text{In put}} = \frac{\text{Work done per second on the vane}}{\text{Initial K.E per second of the jet}} \\ &= \frac{\rho a V_{r_1} V_{w_1} \pm V_{w_2} \times u}{\frac{1}{2} m V_1^2} \end{aligned}$$

Where $m =$ Mass of fluid per second in the jet $= \rho a V_1$

$V_1 =$ Initial velocity of jet

$$\text{Efficiency } \eta = \frac{\rho a V_{r_1} V_{w_1} \pm V_{w_2} \times u}{\frac{1}{2} \rho a V_1 \times V_1^2} \quad \text{----- (8)}$$

PROBLEMS

1. Water is flowing through a pipe at the end of which a nozzle is fitted. The diameter of the nozzle is 100 mm and the head of the water at the centre of the nozzle is 100m. Find the force exerted by the jet of water on a fixed vertical plate. The co-efficient of velocity is given as 0.95.

Given: Diameter of nozzle $d = 100\text{mm} = 0.1\text{m}$

$$\text{Area of nozzle} = \frac{\pi}{4} \times 0.1^2 = 0.00785\text{m}^2$$

Head of water $H = 100\text{m}$

Co-efficient of velocity $C_v = 0.95$

$$\text{Theoretical velocity of jet of water } V_{th} = \sqrt{2gH} = \sqrt{2 \times 9.81 \times 100} =$$

$$44.294\text{m/sec}$$
$$C_v = \frac{\text{Actual velocity}}{\text{Theoretical velocity}}$$

$$\therefore \text{Actual velocity of jet of water} = C_v \times V_{th} = 0.95 \times 44.294 = \mathbf{42.08\text{m/sec}}$$

Force exerted on a fixed vertical plate

$$F = \rho a V^2 = 1000 \times 0.007854 \times 42.08^2$$

$$\mathbf{F = 13907.2\text{ N} = 13.9\text{ kN}}$$

2. A jet of water of diameter 75mm moving with a velocity of 25m/sec strikes a fixed plate in such a way that the angle between the jet and plate is 60° . Find the force exerted by the jet on the plate

- i. In the direction normal to the plate and
- ii. In the direction of the jet.

Given: Diameter of the jet $d = 75\text{mm} = 0.075\text{m}$

$$\text{Area of the jet} = \frac{\pi}{4} \times 0.075^2 = 0.004417\text{m}^2$$

Velocity of jet $V = 25\text{m/sec}$

Angle between jet and plate $\theta = 60^\circ$

i) The force exerted by the jet of water in the direction normal to the plate

$$F_n = \rho a V^2 \sin \theta = 1000 \times 0.004417 \times 25^2 \sin 60^\circ$$

$$\mathbf{F_n = 2390.7\text{ N}}$$

ii) The force in the direction of jet

$$F_x = \rho a V^2 \sin^2 \theta = 1000 \times 0.004417 \times 25^2 \times \sin^2 60^\circ$$

$$\mathbf{F_x = 2070.4\text{ N}}$$

3. A jet of water of dia.50mm moving with a velocity of 40m/sec strikes a curved fixed symmetrical plate at the centre. Find the force exerted by the jet of water in the direction of jet, if the direction of jet is deflected through an angle of 120° at the out let of curved plate.

Given: Dia. of jet $d = 0.05\text{m}$

$$\text{Area of jet } a = \frac{\pi}{4} \times 0.05^2 = 0.001963\text{m}^2$$

Velocity of jet $V = 40\text{m/sec}$

$$\text{Angle of deflection} = 180 - \theta = 180 - 120 = 60^\circ$$

Force exerted by the jet on the curved plate in the direction of jet

$$F_x = \rho a V^2 (1 + \cos \theta)$$

$$F_x = 1000 \times 0.001963 \times 40^2 \times (1 + \cos 60^\circ)$$

$$F_x = 4711.15 \text{ N}$$

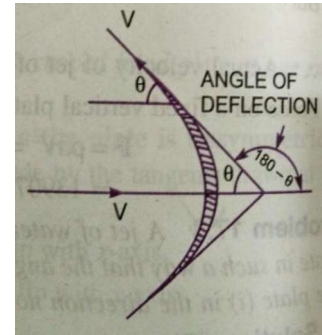

4. A jet of water of dia. 75mm moving with a velocity of 30m/sec strikes a curved fixed plate tangentially at one end at an angle of 30° to the horizontal. The jet leaves the plate at an angle of 20° to the horizontal. Find the force exerted by the jet on the plate in the horizontal and vertical direction.

Given: Dia. of jet $d = 75\text{mm} = 0.075\text{m}$,

$$\text{Area of jet } a = \frac{\pi}{4} \times 0.075^2 = 0.004417 \text{ m}^2$$

Velocity of jet $V = 30\text{m/sec}$

Angle made by the jet at inlet tip with the horizontal $\theta = 30^\circ$

Angle made by the jet at out let tip with the horizontal $\phi = 20^\circ$

The force exerted by the jet of water on the plate in horizontal direction F_x

$$F_x = \rho a V^2 (\cos \theta + \cos \phi)$$

$$= 1000 \times 0.004417 (\cos 30^\circ + \cos 20^\circ) \times 30^2$$

$$F_x = 7178.2 \text{ N}$$

The force exerted by the jet of water on the plate in vertical direction F_y

$$F_y = \rho a V^2 (\sin \theta - \sin \phi)$$

$$= 1000 \times 0.004417 (\sin 30^\circ - \sin 20^\circ) \times 30^2$$

$$F_y = 628.13 \text{ N}$$

5. A nozzle of 50mm dia. delivers a stream of water at 20m/sec perpendicular to the plate that moves away from the plate at 5m/sec. Find:

- i) The force on the plate.
- ii) The work done and
- iii) The efficiency of the jet.

Given: Dia. of jet $d = 50\text{mm} = 0.05\text{m}$,

$$\text{Area of jet } a = \frac{\pi}{4} (0.05)^2 = 0.0019635 \text{ m}^2$$

$$\text{Velocity of jet } V = 20\text{m/sec},$$

$$\text{Velocity of plate } u = 5\text{m/sec}$$

i) The force on the plate $F_x = \rho a V^2 - u^2$

$$F_x = 1000 \times 0.0019635 \times 20^2 - 5^2$$

$$F_x = 441.78 \text{ N}$$

ii) The work done by the jet $= F_x \times u$

$$= 441.78 \times 5$$

$$= 2208.9 \text{ Nm /s}$$

iii) The efficiency of the jet $\eta = \frac{\text{Out put of jet}}{\text{Input of jet}}$

$$= \frac{\text{Work done /sec}}{\text{K.E of jet /sec}} = \frac{F_x \times u}{\frac{1}{2} m v^2}$$

$$= \frac{F_x \times u}{\frac{1}{2} \rho a V^2}$$

$$= \frac{2208.9}{\frac{1}{2} 1000 \times 0.0019635 \times 20^2} = \frac{2208.9}{6540}$$

$$= 0.3377 = 33.77\%$$

6. A 7.5cm dia. jet having a velocity of 30m/sec strikes a flat plate, the normal of which is inclined at 45° to the axis of the jet. Find the normal pressure on the plate:

- i. When the plate is stationary and
- ii. When the plate is moving with a velocity of 15m/sec away from the jet. Also determine the power and efficiency of the jet when the plate is moving.

Given: Dia. of the jet $d = 7.5\text{cm} = 0.075\text{m}$

$$\text{Area of jet } a = \frac{\pi}{4} (0.075)^2 = 0.004417\text{m}^2$$

$$\text{Angle between jet and plate } \theta = 90^\circ - 45^\circ = 45^\circ$$

$$\text{Velocity of jet } V = 30\text{m/sec}$$

i) When the plate is stationary, the normal force F_n on the plate is

$$\begin{aligned} F_n &= \rho a V^2 \sin \theta = 1000 \times 0.004417 \times 30^2 \times \sin 45^\circ \\ &= \mathbf{2810.96\text{ N}} \end{aligned}$$

ii) When the plate is moving with a velocity of 15m/sec away from the jet, the normal force on the plate F_n

$$\begin{aligned} F_n &= \rho a V - u^2 \sin \theta = 1000 \times 0.004417 \times 30 - 15^2 \times \sin 45^\circ \\ &= \mathbf{702.74\text{ N}} \end{aligned}$$

iii) The power and efficiency of the jet, when the plate is moving is obtained as

Work done /sec by the jet

$$= \text{Force in the direction of jet} \times \text{Distance moved by plate in the direction of jet/sec}$$

$$= F_x \times u \quad \text{Where } F_x = F_n \sin \theta = 702.74 \times \sin 45^\circ = 496.9\text{ N}$$

$$\text{Work done/ sec} = 496.9 \times 15 = 7453.5\text{Nm/s}$$

$$\therefore \text{Power in kW} = \frac{\text{Work done /sec}}{1000} = \frac{7453.5}{1000} = \mathbf{7.453\text{ kW}}$$

$$\text{Efficiency of jet} = \frac{\text{Output}}{\text{Input}} = \frac{\text{Work done per sec}}{\text{K.E of jet per sec}}$$

$$= \frac{7453.5}{\frac{1}{2} \rho a V^3} = \frac{7453.5}{\frac{1}{2} \rho a V^3}$$

$$= \frac{7453.5}{\frac{1}{2} \times 1000 \times 0.004417 \times 30^3}$$

$$= \mathbf{0.1249 \approx 0.125 = 12.5\%}$$

7. A jet of water of dia. 7.5cm strikes a curved plate at its centre with a velocity of 20m/sec. the curved plate is moving with a velocity of 8m/sec in the direction of the jet. The jet is deflected through an angle of 165°. Assuming plate is smooth, find

- i. Force exerted on the plate in the direction of jet.
- ii. Power of jet.
- iii. Efficiency of jet.

Given: Dia. of jet $d = 7.5\text{cm} = 0.075\text{m}$

$$\text{Area of jet } a = \frac{\pi}{4} (0.075)^2 = 0.004417\text{m}^2$$

$$\text{Velocity of jet } V = 20\text{m/sec}$$

$$\text{Velocity of plate } u = 8\text{m/sec}$$

Angle made by the relative velocity at the out let of the plate $\theta = 180^\circ - 165^\circ = 15^\circ$

i) Force exerted by the jet on the plate in the direction of jet

$$F_x = \rho a V^2 (1 + \cos \theta)$$

$$\begin{aligned} F_x &= 1000 \times 0.004417 \times 20^2 (1 + \cos 15^\circ) \\ &= \mathbf{1250.38N} \end{aligned}$$

ii) Work done by the jet on the plate per second

$$\begin{aligned} &= F_x \times u \\ &= 1250.38 \times 8 \\ &= \mathbf{10003.04 Nm/s} \end{aligned}$$

$$\therefore \text{Power of jet} = \frac{10003.04}{1000} = 10\text{kW}$$

iii) Efficiency of the jet = $\frac{\text{Output}}{\text{Input}} = \frac{\text{Work done per sec}}{\text{K.E of jet per sec}}$

$$= \frac{1250.38 \times 8}{\frac{1}{2} \rho a V^3} = \frac{1250.38 \times 8}{\frac{1}{2} \times 1000 \times 0.004417 \times (20)^3}$$

$$= \mathbf{0.564 = 56.4\%}$$

8. A jet of water having a velocity of 40m/sec strikes a curved vane, which is moving with a velocity of 20m/sec. The jet makes an angle of 30° with the direction of motion of vane at inlet and leaves at an angle of 90° to the direction of motion of vane at outlet. Draw velocity triangles at inlet and outlet and determine vane angles at inlet and outlet, so that the water enters and leaves the vanes without shock.

Given: Velocity of jet $V_1 = 40\text{m/sec}$
 Velocity of vane $u_1 = 20\text{m/sec}$
 Angle made by jet at inlet $\alpha = 30^\circ$
 Angle made by leaving jet = 90°
 $\therefore \beta = 180^\circ - 90^\circ = 90^\circ$
 $u_1 = u_2 = u = 20\text{m/sec}$

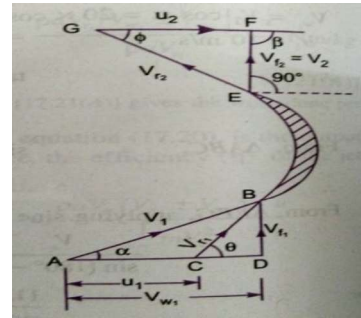

Vane angles at inlet and outlet are θ and ϕ

From ΔBCD we have $\tan \theta = \frac{BD}{CD} = \frac{BD}{AD-AC} = \frac{V_{f1}}{V_{w1}-u_1}$

Where $V_{f1} = V_1 \sin \alpha = 40 \times \sin 30^\circ = 20\text{m/s}$

$V_{w1} = V_1 \cos \alpha = 40 \times \cos 30^\circ = 34.64\text{ m/s}$

$u_1 = 20\text{m/s}$

$\therefore \tan \theta = \frac{20}{34.64-20} = \frac{20}{14.64} = 1.366 = \tan 53.79^\circ$

$\therefore \theta = 53.79^\circ \text{ or } 53^\circ 47.4'$

Also from ΔBCD we have $\sin \theta = \frac{V_{f1}}{V_{r1}}$ or $V_{r1} = \frac{1}{\sin \theta} = \frac{20}{\sin 53.79^\circ} = 24.78 \text{ m/s}$

$\therefore V_{r1} = 24.78\text{m/s}$

But $V_{r2} = V_{r1} = 24.78$

Hence, From ΔEFG , $\cos \phi = \frac{2}{24.78} = \frac{20}{24.78} = 0.8071 = \cos 36.18^\circ$

$\phi = 36.18^\circ \text{ or } 36^\circ 10.8'$

9. A stationary vane having an inlet angle of zero degree and an outlet angle of 25° , receives water at a velocity of 50m/sec. Determine the components of force acting on it in the direction of jet velocity and normal to it. Also find the resultant force in magnitude and direction per unit weight of the flow.

Given: Velocity of jet $V = 50\text{m/sec}$

Angle at outlet $= 25^\circ$

For the stationary vane, the force in the direction of jet.

$$F_x = \text{Mass per sec} \times V_{1x} - V_{2x}$$

Where $V_{1x} = 50\text{m/sec}$, $V_{2x} = -50 \cos 25^\circ = -45.315$

\therefore Force in the direction of jet per unit weight of water F_x

$$F_x = \frac{\text{Mass / sec} [50 - (-45.315)]}{\text{Weig } \frac{\text{t of water}}{\text{sec}}} = \frac{\text{Mass / sec} [50 + 45.315]}{\text{mass / sec} \times g}$$

$$= \frac{95.315}{9.81} = 9.716 \text{ N/N}$$

Force exerted by the jet in perpendicular direction to the jet per unit weight of flow

$$V_{1y} = 0 \quad V_{2y} = 50 \sin 25^\circ$$

$$F_y = \frac{\text{Mass / sec} (V_{1y} - V_{2y})}{g \times \text{mass per sec}}$$

$$= \frac{(0 - 50 \sin 25^\circ)}{g} = \frac{-50 \sin 25^\circ}{9.81}$$

$$= -2.154 \text{ N}$$

- ve sign means the force F_y is acting in the downward direction.

\therefore Resultant Force per unit weight of water $F_R = \sqrt{F_x^2 + F_y^2}$

$$F_R = \sqrt{(9.716)^2 + (2.154)^2} = 9.952 \text{ N}$$

The angle made by the Resultant Force with x - axis

$$\tan \theta = \frac{F_y}{F_x} = \frac{2.154}{9.716} = 0.2217$$

$$\theta = \tan^{-1} 0.2217 = 12.50^\circ$$

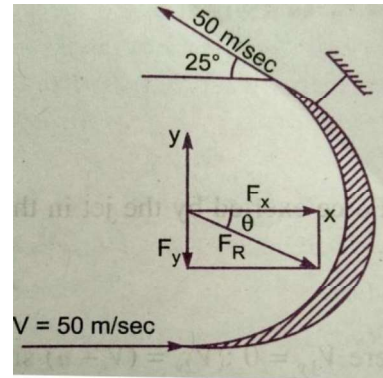

10. A jet of water diameter 50mm moving with a velocity of 25m/sec impinges on a fixed curved plate tangentially at one end at an angle of 30° to the horizontal. Calculate the resultant force of the jet on the plate, if the jet is deflected through an angle of 50° . Take $g=10\text{m/sec}^2$.

Given:

Dia. of jet $d = 50\text{mm} = 0.05\text{m}$,

$$\text{Area of jet } a = \frac{\pi}{4}(0.05)^2 = 0.0019635 \text{ m}^2$$

Velocity of jet $V = 25\text{m/sec}$,

Angle made by the jet at inlet with horizontal $\theta = 30^\circ$

Angle of deflection = 50°

Angle made by the jet at the outlet with horizontal ϕ

$$\phi = + \text{angle of deflection} = 30^\circ + 50^\circ = 80^\circ \text{ The}$$

Force exerted by the jet of water in the direction of x

$$F_x = \rho a V V_{1x} - V_{2x}$$

Where

$$\rho = 1000$$

$$= \frac{\pi}{4} 0.05^2 \quad V = 25 \text{ m/s}$$

$$V_{1x} = V \cos 30^\circ = 25 \cos 30^\circ$$

$$V_{2x} = V \cos 80^\circ = 25 \cos 80^\circ$$

$$F_x = 1000 \times \frac{\pi}{4} 0.05^2 \times 25 (25 \cos 30^\circ - 25 \cos 80^\circ) = \mathbf{849.7 \text{ N}}$$

The Force exerted by the jet of water in the direction of y

$$F_y = \rho a V V_{1y} - V_{2y}$$

$$F_y = 1000 \times \frac{\pi}{4} 0.05^2 \times 25 (25 \sin 30^\circ - 25 \sin 80^\circ) = \mathbf{-594.9 \text{ N}}$$

- ve sign shows that Force F_y is acting in the downward direction.

The Resultant force

$$F_R = \sqrt{F_x^2 + F_y^2}$$

$$= \sqrt{(849.7)^2 + (594.9)^2}$$

$$= \mathbf{1037\text{N}}$$

Angle made by the Resultant Force with the Horizontal

$$\tan \alpha = \frac{F_y}{F_x} = \frac{594.9}{849.7} = 0.7$$

$$\alpha = \tan^{-1} 0.7 = \mathbf{35^\circ}$$

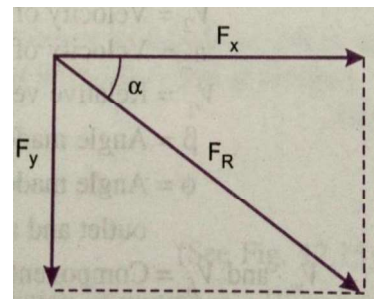
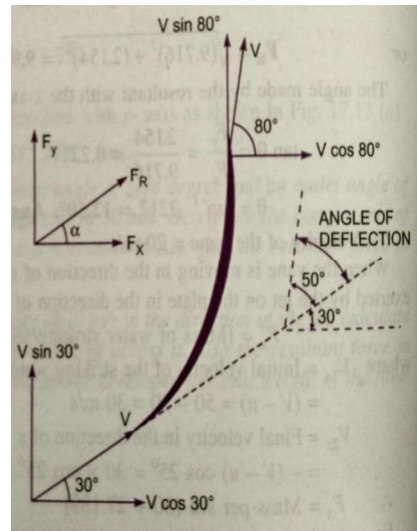

HYDRAULIC TURBINES

Turbines are defined as the hydraulic machines which convert hydraulic energy into mechanical energy. This mechanical energy is used in running an electric generator which is directly coupled to the shaft of the turbine. Thus, mechanical energy is converted into electrical energy. The electric power which is obtained from the hydraulic energy is known as the hydro-electric power.

Efficiency of a Turbine: The following are the important efficiencies of a turbine.

- a) Hydraulic Efficiency, η_h
- b) Mechanical Efficiency, η_m
- c) Volumetric Efficiency, η_v
- d) Overall Efficiency, η_o

a) Hydraulic Efficiency (η_h): It is defined as the ratio of power given by the water to the runner of a turbine (runner is a rotating part of a turbine and on the runner vanes are fixed) to the power supplied by the water at the inlet of the turbine. The power at the inlet of the turbine is more and this power goes on decreasing as the water flows over the vanes of the turbine due to hydraulic losses as the vanes are not smooth. Hence, power delivered to the runner of the turbine will be less than the power available at the inlet of the turbine.

$$\eta_h = \frac{\text{Power delivered to the runner}}{\text{Power supplied at inlet}} = \frac{\text{R.P}}{\text{W.P}}$$

$$\text{R.P} = \text{Power delivered to the runner} = \frac{W}{g} \frac{[V_{w1} + V_{w2}] \times u}{1000} \quad \text{kW} \text{ ----- for Pelton Turbine}$$

$$= \frac{W}{g} \frac{[V_{w1} u_1 + V_{w2} u_2] \times u}{1000} \quad \text{kW} \text{ ----- Radial flow Turbine.}$$

$$\text{W.P} = \text{power supplied at inlet of turbine} = \frac{W \times H}{1000} \quad \text{kW}$$

Where W = weight of water striking the vanes of the turbine per second = $\rho g Q$

Q = Volume of water per second

V_{w1} = Velocity of whirl at inlet.

V_{w2} = Velocity of whirl at outlet

u = Tangential velocity of vane

u_1 = Tangential velocity of vane at inlet of radial vane.

u_2 = Tangential velocity of vane at outlet of radial vane.

H = Net head on the turbine.

Power supplied at the inlet of the turbine in S I Units is known as Water Power.

$$W.P = \frac{\rho \times g \times Q \times H}{1000} \text{ K.W} \quad (\text{For water } \rho = 1000 \text{Kg/m}^3)$$

$$= \frac{1000 \times g \times Q \times H}{1000} = g \times Q \times H \text{ kW}$$

b) Mechanical Efficiency (η_m): The power delivered by the water to the runner of a turbine is transmitted to the shaft of the turbine. Due to mechanical losses, the power available at the shaft of the turbine is less than the power delivered to the runner of the turbine. The ratio of power available at the shaft of the turbine (Known as S.P or B.P) to the power delivered to the runner is defined as Mechanical efficiency.

$$\eta_m = \frac{\text{Power at the shaft of the turbine}}{\text{Power delivered by the water to the runner}} = \frac{S.P}{R.P}$$

c) Volumetric Efficiency (η_v): The volume of the water striking the runner of the turbine is slightly less than the volume of water supplied to the turbine. Some of the volume of the water is discharged to the tailrace without striking the runner of the turbine. Thus the ratio of the volume of the water supplied to the turbine is defined as Volumetric Efficiency.

$$\eta_v = \frac{\text{Volume of water actually striking the Runner}}{\text{Volume of water supplied to the Turbine}}$$

d) Overall Efficiency (η_o): It is defined as the ratio of power available at the shaft of the turbine to the power supplied by the water at the inlet of the turbine.

$$\eta_o = \frac{\text{Power available at the shaft of the turbine}}{\text{Power supplied at the inlet of the turbine}} = \frac{\text{Shaft power}}{\text{Water power}}$$

$$= \frac{S.P}{W.P} = \frac{S.P}{W.P} \times \frac{R.P}{R.P}$$

$$= \frac{S.P}{R.P} \times \frac{R.P}{W.P}$$

$$\eta_o = \eta_m \times \eta_h$$

If shaft power (S.P) is taken in kW, Then water power should also be taken in kW. Shaft power is represented by P.

Water power in $kW = \frac{\rho \times g \times Q \times H}{1000}$

Where $\rho = 1000 \text{Kg/m}^3$

$$\eta_o = \frac{\text{Shaft Power in kW}}{\text{Water Power in kW}} = \frac{P}{\frac{\rho \times g \times Q \times H}{1000}}$$

Where P = Shaft Power

CLASSIFICATION OF HYDRAULIC TURBINES:

The Hydraulic turbines are classified according to the type of energy available at the inlet of the turbine, direction of flow through the vanes, head at the inlet of the turbine and specific speed of the turbine. The following are the important classification of the turbines.

1. According to the type of energy at inlet:
 - (a) Impulse turbine and
 - (b) Reaction turbine
2. According to the direction of flow through the runner:
 - (a) Tangential flow turbine
 - (b) Radial flow turbine.
 - (c) Axial flow turbine
 - (d) Mixed flow turbine.
3. According to the head at inlet of the turbine:
 - (a) High head turbine
 - (b) Medium head turbine and
 - (c) Low head turbines.
4. According to the specific speed of the turbine:
 - (a) Low specific speed turbine
 - (b) Medium specific speed turbine
 - (c) High specific speed turbine.

If at the inlet of turbine, the energy available is only kinetic energy, the turbine is known as **Impulse turbine**. As the water flows over the vanes, the pressure is atmospheric from inlet to outlet of the turbine. If at the inlet of the turbine, the water possesses kinetic energy as well as pressure energy, the turbine is known as **Reaction turbine**. As the water flows through runner, the water is under pressure and the pressure energy goes on changing in to kinetic energy. The runner is completely enclosed in an air-tight casing and the runner and casing is completely full of water.

If the water flows along the tangent of runner, the turbine is known as **Tangential flow turbine**. If the water flows in the radial direction through the runner, the turbine is called **Radial flow turbine**. If the water flows from outward to inwards radially, the turbine is known as **Inward** radial flow turbine, on the other hand, if the water flows radially from inward to outwards, the turbine is known as **outward** radial flow turbine. If the water flows through the runner along the direction parallel to the axis of rotation of the runner, the turbine is called **axial flow** turbine. If the water flows through the runner in the radial direction but leaves in the direction parallel to the axis of rotation of the runner, the turbine is called **mixed flow** turbine.

PELTON WHEEL (Turbine)

It is a tangential flow impulse turbine. The water strikes the bucket along the tangent of the runner. The energy available at the inlet of the turbine is only kinetic energy. The pressure at the inlet and outlet of turbine is atmospheric. This turbine is used for high heads and is named after L.A.Pelton an American engineer.

The water from the reservoir flows through the penstocks at the outlet of which a nozzle is fitted. The nozzle increases the kinetic energy of the water flowing through the penstock. At the outlet of the nozzle, the water comes out in the form of a jet and strikes the buckets (vanes) of the runner. The main parts of the Pelton turbine are:

1. Nozzle and flow regulating arrangement (spear)
2. Runner and Buckets.
3. Casing and
4. Breaking jet

1. Nozzle and flow regulating arrangement: The amount of water striking the buckets (vanes) of the runner is controlled by providing a spear in the nozzle. The spear is a conical needle which is operated either by hand wheel or automatically in an axial direction depending upon the size of the unit. When the spear is pushed forward into the nozzle, the amount of water striking the runner is reduced. On the other hand, if the spear is pushed back, the amount of water striking the runner increases.

2. Runner with buckets: It consists of a circular disc on the periphery of which a number of buckets evenly spaced are fixed. The shape of the buckets is of a double hemispherical cup or bowl. Each bucket is divided into two symmetrical parts by a dividing wall, which is known as splitter.

The jet of water strikes on the splitter. The splitter divides the jet into two equal parts and the jet comes out at the outer edge of the bucket. The buckets are shaped in such a way that the jet gets deflected through an angle of 160° or 170° . The buckets are made of cast Iron, cast steel, Bronze or stainless steel depending upon the head at the inlet of the turbine.

3. Casing: The function of casing is to prevent the splashing of the water and to discharge the water to tailrace. It also acts as safeguard against accidents. It is made of Cast Iron or fabricated steel plates. The casing of the Pelton wheel does not perform any hydraulic function.

4. Breaking jet: When the nozzle is completely closed by moving the spear in the forward direction, the amount of water striking the runner reduces to zero. But the runner due to inertia goes on revolving for a long time. To stop the runner in a short time, a small nozzle is provided, which directs the jet of water on the back of the vanes. This jet of water is called Breaking jet.

Velocity triangles and work done for Pelton wheel:

The jet of water from the nozzle strikes the bucket at the splitter, which splits up the jet into two parts. These parts of the jet, glide over the inner surfaces and comes out at the outer edge. The splitter is the inlet tip and outer edge of the bucket is the outlet tip of the bucket. The inlet velocity triangle is drawn at the splitter and outlet velocity triangle is drawn at the outer edge of the bucket.

Let

H = Net head acting on the Pelton Wheel

$$= H_g - h_f$$

Where H_g = Gross Head

$$h_f = \frac{4fLV^2}{D^5 \times 2g}$$

Where D^* = diameter of penstock,

D = Diameter of wheel,

d = Diameter of Jet,

N = Speed of the wheel in r.p.m

Then V_1 = Velocity of jet at inlet

$$= \sqrt{2gH}$$

$$u = u_1 = u_2 = \frac{\pi DN}{60}$$

The Velocity Triangle at inlet will be a straight line where

$$V_{r_1} = V_1 - u_1 = V_1 - u$$

$$V_{w_1} = V_1 \quad \alpha = 0^\circ \quad \text{and} \quad \theta = 0^\circ$$

From the velocity triangle at outlet, we have

$$V_{r_2} = V_{r_1} \text{ and } V_{w_2} = V_{r_2} \cos \phi - u_2$$

The force exerted by the Jet of water in the direction of motion is

$$F_x = \rho a V_1 [V_{w_1} + V_{w_2}] \quad \text{-----} (1)$$

As the angle β is an acute angle, +ve sign should be taken. Also this is the case of series of vanes, the mass of water striking is $\rho a V_1$ and not $\rho a V_{r_1}$. In equation (1) „a“ is the area of the jet $= \frac{\pi}{4} d^2$

Now work done by the jet on the runner per second

$$= F_x \times u = \rho a V_1 [V_{w_1} + V_{w_2}] \times u \quad \text{Nm/s}$$

$$\text{Power given to the runner by the jet} = \frac{\rho a V_1 [V_{w_1} + V_{w_2}] \times u}{1000} \text{ kW}$$

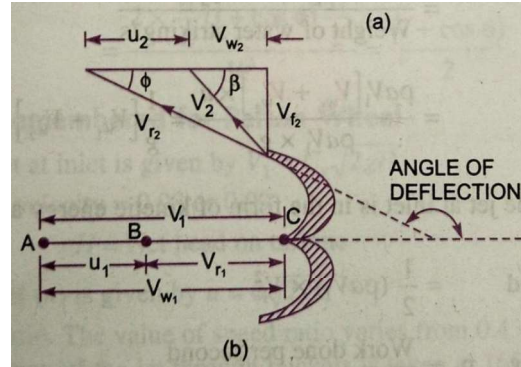

$$\begin{aligned} \text{Work done/s per unit weight of water striking/s} &= \frac{\rho a V_1 [V_{w_1} + V_{w_2}] \times u}{\text{Weight of water striking/s}} \\ &= \frac{\rho a V_1 [V_{w_1} + V_{w_2}] \times u}{\rho a V_1 \times g} = \frac{1}{g} [V_{w_1} + V_{w_2}] \times u \quad \text{--- (3)} \end{aligned}$$

The energy supplied to the jet at inlet is in the form of kinetic energy

$$\therefore \text{K.E. of jet per second} = \frac{1}{2} m V^2 = \frac{1}{2} (\rho a V_1) \times V_1^2$$

$$\therefore \text{Hydraulic efficiency, } \eta_h = \frac{\text{Work done per second}}{\text{K.E. of jet per second}}$$

$$\begin{aligned} &= \frac{\rho a V_1 [V_{w_1} + V_{w_2}] \times u}{\frac{1}{2} (\rho a V_1) \times V_1^2} \\ &= \frac{2 [V_{w_1} + V_{w_2}] \times u}{V_1^2} \quad \text{--- (4)} \end{aligned}$$

$$\text{Now } V_{w_2} = V_1 \text{ and } V_{r_2} = V_1 - u_1 = (V_1 - u)$$

$$\therefore V_{r_2} = (V_1 - u)$$

$$\text{And } V_{w_2} = V_{r_2} \cos \phi - u_2$$

$$\begin{aligned} &= V_{r_2} \cos \phi - u \\ &= (V_1 - u) \cos \phi - u \end{aligned}$$

Substituting the values of V_{w_2} and V_{r_2} in equation (4)

$$\begin{aligned} \eta_h &= \frac{2 [V_1 + (V_1 - u) \cos \phi - u] \times u}{V_1^2} = \frac{2 [V_1 - u + (V_1 - u) \cos \phi] \times u}{V_1^2} \\ &= \frac{2 (V_1 - u) [1 + \cos \phi] u}{V_1^2} \quad \text{--- (5)} \end{aligned}$$

The efficiency will be maximum for a given value of V_1 when

$$\frac{d}{du} (\eta_h) = 0 \text{ or } \frac{d}{du} \left[\frac{2u(V_1 - u)[1 + \cos \phi]}{V_1^2} \right] = 0$$

$$\text{Or } \frac{(1 + \cos \phi)}{V_1^2} \frac{d}{du} (2uV_1 - 2u^2) = 0$$

$$\text{Or } \frac{d}{du} [2uV_1 - 2u^2] = 0 \quad \left(\because \frac{1 + \cos \phi}{V_1^2} \neq 0 \right)$$

$$\text{Or } 2V_1 - 4u = 0 \quad \text{Or } u = \frac{V_1}{2} \quad \text{--- (6)}$$

Equation (6) states that hydraulic efficiency of a Pelton wheel will be maximum when the velocity of the wheel is half the velocity of the jet water at inlet. The expression for maximum efficiency will be obtained by substituting the value of $u = \frac{V_1}{2}$ in equation (5)

$$\text{Max. } \eta_h = \frac{2 \left(V_1 - \frac{V_1}{2} \right) (1 + \cos \phi) \times \frac{V_1}{2}}{V_1^2}$$

$$= \frac{2 \times \frac{V_1}{2} (1 + \cos \phi) \frac{V_1}{2}}{V_1^2} = \frac{(1 + \cos \phi)}{2} \quad \text{-----(7)}$$

RADIAL FLOW REACTION TURBINE:

In the Radial flow turbines water flows in the radial direction. The water may flow radially from outwards to inwards (i.e. towards the axis of rotation) or from inwards to outwards. If the water flows from outwards to inwards through the runner, the turbine is known as **inwards radial flow turbine**. And if the water flows from inwards to outwards, the turbine is known as **outward radial flow turbine**.

Reaction turbine means that the water at the inlet of the turbine possesses kinetic energy as well as pressure energy. As the water flows through the runner, a part of pressure energy goes on changing into kinetic energy. Thus the water through the runner is under pressure. The runner is completely enclosed in an air-tight casing and the runner is always full of water.

Main parts of a Radial flow Reaction turbine:

1. Casing
2. Guide mechanism
3. Runner and
4. Draft tube.

1. Casing: in case of reaction turbine, casing and runner are always full of water. The water from the penstocks enters the casing which is of spiral shape in which area of cross-section one of the casing goes on decreasing gradually. The casing completely surrounds the runner of the turbine. The water enters the runner at constant velocity throughout the circumference of the runner.

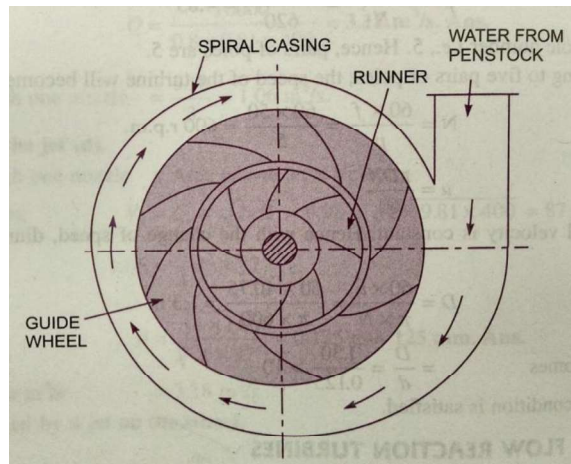

2. Guide Mechanism: It consists of a stationary circular wheel all around the runner of the turbine. The stationary guide vanes are fixed on the guide mechanism. The guide vanes allow the water to strike the vanes fixed on the runner without shock at inlet. Also by suitable arrangement, the width between two adjacent vanes of guide mechanism can be altered so that the amount of water striking the runner can be varied.

3. Runner: It is a circular wheel on which a series of radial curved vanes are fixed. The surfaces of the vanes are made very smooth. The radial curved vanes are so shaped that the water enters and leaves the runner without shock. The runners are made of cast steel, cast iron or stain less steel. They are keyed to the shaft.

4. Draft - Tube: The pressure at the exit of the runner of a reaction turbine is generally less than atmospheric pressure. The water at exit can't be directly discharged to the tail race. A tube or pipe of gradually increasing area is used for discharging the water from the exit of the turbine to the tail race. This tube of increasing area is called draft-tube.

Inward Radial Flow Turbine: In the inward radial flow turbine, in which case the water from the casing enters the stationary guiding wheel. The guiding wheel consists of guide vanes which direct the water to enter the runner which consists of moving vanes. The water flows over the moving vanes in the inward radial direction and is discharged at the inner

diameter of the runner. The outer diameter of the runner is the inlet and the inner diameter is the outlet.

Velocity triangles and work done by water on runner:

Work done per second on the runner by water

$$= \rho a V_1 [V_{w_1} u_1 \pm V_{w_2} u_2]$$

$$= \rho Q [V_{w_1} u_1 \pm V_{w_2} u_2] \quad \text{_____ (1)} \quad (\because a V_1 = Q)$$

The equation represents the energy transfer per second to the runner.

Where V_{w_1} = Velocity of whirl at inlet
 V_{w_2} = Velocity of whirl at outlet
 u_1 = Tangential velocity at inlet
 $= \frac{\pi D_1 \times N}{60}$, Where D_1 = Outer dia. Of runner,
 u_2 = Tangential velocity at outlet
 $= \frac{\pi D_2 \times N}{60}$

Where D_2 = Inner dia. Of runner,

N = Speed of the turbine in r.p.m.

The work done per second per unit weight of water per second

$$= \frac{\text{work done per second}}{\text{weight of water striking per second.}}$$

$$= \frac{\rho Q [V_{w_1} u_1 \pm V_{w_2} u_2]}{\rho Q \times g}$$

$$= \frac{1}{g} [V_{w_1} u_1 \pm V_{w_2} u_2] \quad \text{_____ (2)}$$

Equation (2) represents the energy transfer per unit weight/s to the runner. This equation is known by **Euler's equation**.

In equation +ve sign is taken if β is an acute angle,
 -ve sign is taken if β is an obtuse angle.

If $\beta = 90^\circ$ then $V_{w_2} = 0$ and work done per second per unit weight of water striking/s

$$\text{Work done} = \frac{1}{g} V_{w_1} u_1$$

Hydraulic efficiency $\eta_h = \frac{R.P.}{W.P.} = \frac{\text{Power delivered to runner}}{\text{Power supplied at inlet}}$

$$= \frac{\frac{W}{1000 \times g} [V_{w_1} u_1 \pm V_{w_2} u_2]}{\frac{W \times H}{1000}} = \frac{(V_{w_1} u_1 \pm V_{w_2} u_2)}{gH} \quad \text{_____ (3)}$$

Where R.P. = Runner Power i.e. power delivered by water to the runner

W.P. = Water Power

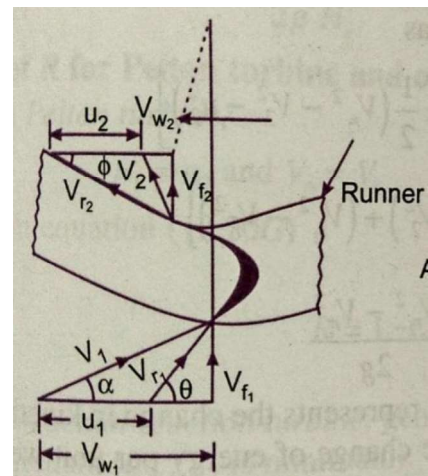
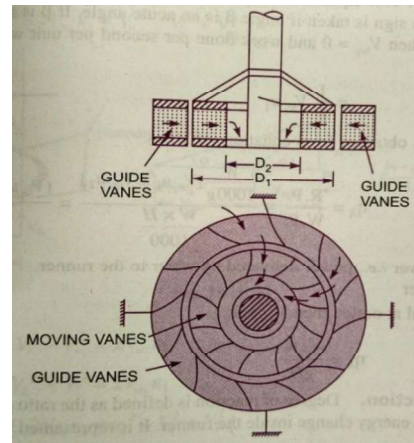

If the discharge is radial at outlet, then $V_{w_2} = 0$

$$\eta_h = \frac{V_{w_1} u_1}{gH}$$

Definitions:

The following terms are generally used in case of reaction radial flow turbines which are defined as:

1. Speed Ratio: The speed ratio is defined as = $\frac{u_1}{\sqrt{2gH}}$

Where u_1 = tangential velocity of wheel at inlet

2. Flow Ratio: The ratio of velocity of flow at inlet (V_{f_1}) to the velocity given $\sqrt{2gH}$ is known as the flow ratio.

$$= \frac{V_{f_1}}{\sqrt{2gH}}$$

Where H = Head on turbine

3. Discharge of the turbine: The discharge through a reaction radial flow turbine is

$$Q = \pi D_1 B_1 \times V_{f_1} = \pi D_2 B_2 \times V_{f_2}$$

Where D_1 = Dia of runner at inlet

D_2 = Dia of runner at outlet

B_1 = Width of the runner at inlet

B_2 = Width of runner at outlet

V_{f_1} = Velocity of flow at inlet

V_{f_2} = Velocity of flow at outlet

If the thickness of the vanes are taken into consideration then the area through which flow takes place is given by

$$= \pi D_1 - n \times t$$

Where n = Number of vanes and

t = Thickness of each vane

4. Head: The (H) on the turbine is given by

$$H = \frac{P_1}{\rho g} + \frac{V_1^2}{2g}$$

Where P_1 = Pressure at inlet

5. Radial Discharge: This means the angle made by absolute velocity with the tangent on the wheel is 90° and the component of whirl velocity is zero. The radial discharge at outlet means $\beta = 90^\circ$ and $V_{w_2} = 0$ while radial discharge at inlet means $\alpha = 90^\circ$ and $V_{w_2} = 0$

6. If there is no loss of energy when the water flows through the vanes then we have

$$H - \frac{V_2^2}{2g} = \frac{1}{g} [V_{w_1}u_1 \pm V_{w_2}u_2]$$

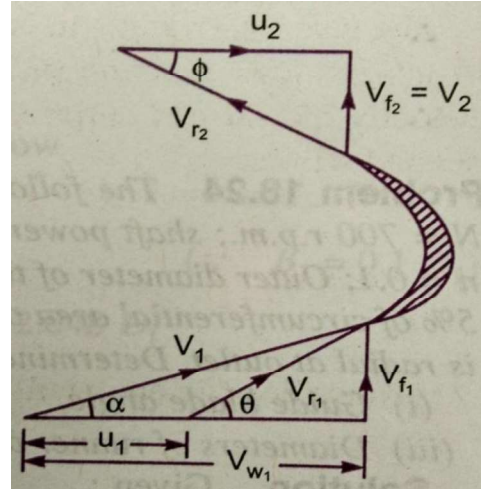

FRANCIS TURBINE:

The inward flow reaction turbine having radial discharge at outlet is known as Francis Turbine. The water enters the runner of the turbine in the radial direction at outlet and leaves in the axial direction at the inlet of the runner. Thus the Francis turbine is a mixed flow type turbine.

The velocity triangle at inlet and outlet of the Francis turbine are drawn in the same way as in case of inward flow reaction turbine. As in case of inward radial flow turbine. The discharge of Francis turbine is radial at outlet; the velocity of whirl at outlet (V_{w_2}) will be zero. Hence the work done by water on the runner per second will be

$$= \rho Q [V_{w_1}u_1]$$

The work done per second per unit weight of water striking/sec = $\frac{1}{g} [V_{w_1}u_1]$

Hydraulic efficiency $\eta_h = \frac{V_{w_1}u_1}{gH}$

Important relations for Francis turbines:

1. The ratio of width of the wheel to its diameter is given

as $n = \frac{B_1}{D_1}$. The value of n varies from 0.10 to 0.40

2. The flow ratio is given as

Flow ratio = $\frac{V_{f_1}}{\sqrt{2gH}}$ and varies from 0.15 to 0.30

3. The speed ratio = $\frac{u_1}{\sqrt{2gH}}$ varies from 0.6 to 0.9

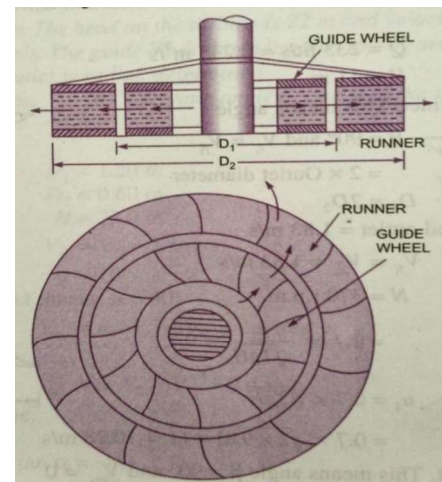

Outward radial Flow Reaction Turbine:

In the outward radial flow reaction turbine water from the casing enters the stationary guide wheel. The guide wheel consists of guide vanes which direct the water to enter the runner which is around the stationary guide wheel. The water flows through the vanes of the runner in the outward radial direction and is discharged at the outer diameter of the runner. The inner diameter of the runner is inlet and outer diameter is the outlet.

The velocity triangles at inlet and outlet will be drawn by the same procedure as adopted for inward flow turbine. The work done by the water on the runner per second, the horse power developed and hydraulic efficiency will be obtained from the velocity triangles. In this case as the inlet of the runner is at the inner diameter of the runner, the tangential velocity at inlet will be less than that of an outlet. i.e.

$$u_1 < u_2 \quad \text{As } D_1 < D_2 \text{ All}$$

the working conditions flow through the runner blades without shock. As such eddy losses which are inevitable in Francis and propeller turbines are almost completely eliminated in a Kaplan turbine.

The discharge through the runner is obtained as

$$Q = \frac{\pi}{4} (D_0^2 - D_b^2) \times V_{f_2}$$

Where D_0 = outer diameter of the runner

D_b = Diameter of the hub

V_{f_2} = Velocity of flow at inlet

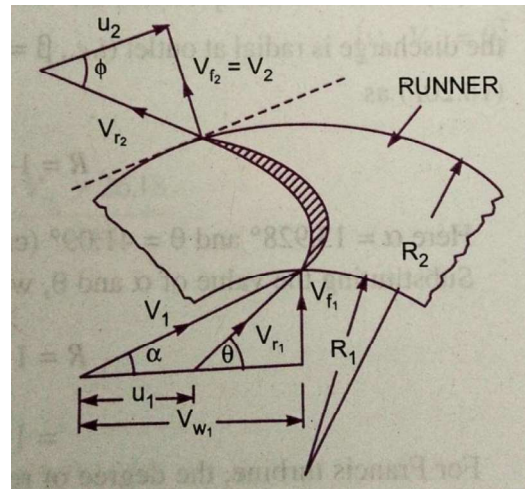

Important points for Kaplan turbine:

1. The peripheral velocity at inlet and outlet are equal.

$$u_1 = u_2 = \frac{\pi D_0 N}{60}$$

Where D_0 = Outer diameter of runner.

2. Velocity of flow at inlet and outlet are equal.

$$V_{f_1} = V_{f_2}$$

3. Area of flow at inlet = Area of flow at outlet

$$= \frac{\pi}{4} (D_0^2 - D_b^2)$$

AXIAL FLOW REACTION TURBINE:

If the water flows parallel to the axis of the rotation shaft the turbine is known as axial flow turbine. If the head at inlet of the turbine is the sum of pressure energy and kinetic energy and during the flow of the water through the runner a part of pressure energy is converted into kinetic energy, the turbine is known as reaction turbine.

For axial flow reaction turbine, the shaft of the turbine is vertical. The lower end of the shaft is made longer known as “hub” or “boss”. The vanes are fixed on the hub and act as a runner for the axial flow reaction turbine. The important types of axial flow reaction turbines are:

1. Propeller Turbine
2. Kaplan Turbine

When the vanes are fixed to the hub and they are not adjustable the turbine is known as propeller turbine. But if the vanes on the hub are adjustable, the turbine is known as Kaplan turbine. This turbine is suitable where large quantity of water at low heads is available.

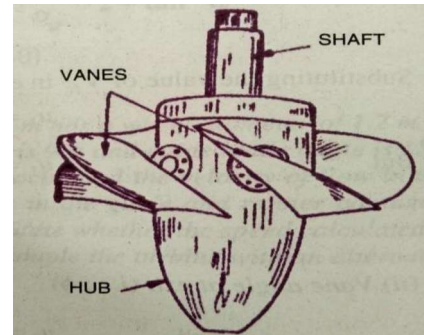

The main parts of the Kaplan turbine are:

1. Scroll casing
2. Guide vanes mechanism
3. Hub with vanes or runner of the turbine
4. Draft tube

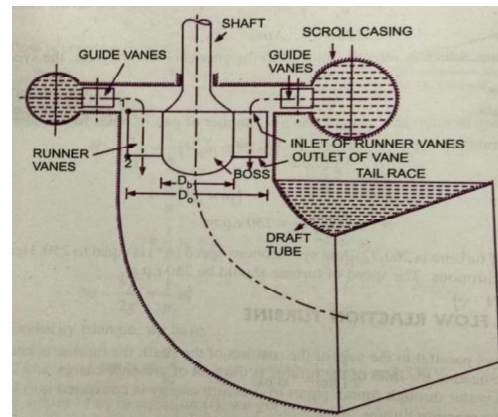

Between the guide vanes and the runner the water in the Kaplan turbine turns through a right angle in to the axial angle direction and then passes through the runner. The runner of the Kaplan turbine has four or six or eight in some cases blades and it closely resembles a ship's propeller. The blades (vanes) attached to a hub or bosses are so shaped that water flows axially through the runner.

The runner blades of a propeller turbine are fixed but the Kaplan turbine runner heads can be turned about their own axis, so that their angle of inclination may be adjusted while the turbine is in motion. The adjustment of the runner blades is usually carried out automatically by means of a servomotor operating inside the hollow coupling of turbine and generator shaft. When both guide vane angle and runner blade angle may thus be varied a

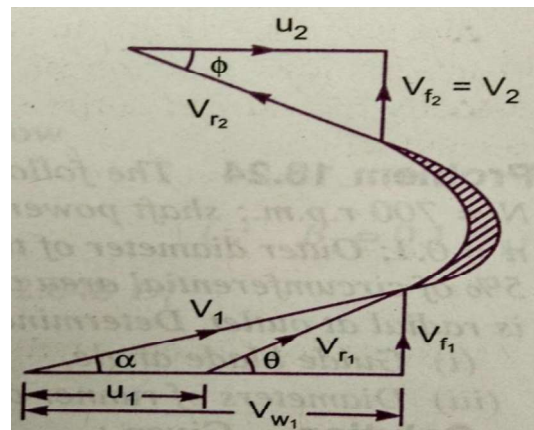

high efficiency can be maintained over a wide range of operating conditions. i.e. even at part load, when a lower discharge is following through the runner a high efficiency can be attained in case of Kaplan turbine. The flow through turbine runner does not affect the shape of velocity triangles as blade angles are simultaneously adjusted, the water under all the working conditions flows through the runner blades without shock. The eddy losses which are inevitable in Francis and propeller turbines are completely eliminated in a Kaplan Turbine.

Working Proportions of Kaplan Turbine:

The main dimensions of Kaplan Turbine runners are similar to Francis turbine runner. However the following are main deviations,

- i. Choose an appropriate value of the ratio $n = \frac{d}{D}$, where d is hub or boss diameter and D is runner outside diameter. The value of n varies from 0.35 to 0.6

- ii. The discharge Q flowing through the runner is given by

$$Q = \frac{\pi}{4} (D^2 - d^2) V_f = \frac{\pi}{4} (D^2 - d^2) \psi \sqrt{2gH}$$

The value of flow ratio ψ for a Kaplan turbine is 0.7

- iii. The runner blades of the Kaplan turbine are twisted, the blade angle being greater at the outer tip than at the hub. This is because the peripheral velocity of the blades being directly proportional to radius. It will vary from section to section along the blade, and hence in order to have shock free entry and exit of water over the blades with angles varying from section to section will have to be designed.

DRAFT TUBE:

The draft tube is a pipe of gradually increasing area, which connects the outlet of the runner to the tail race. It is used for discharging water from the exit of the turbine to the tail race. This pipe of gradually increasing area is called a draft tube. One end of the draft tube is connected to the outlet of the runner and the other end is submerged below the level of water in the tail race. The draft tube in addition to save a passage for water discharge has the following two purposes also:

1. It permits a negative head to be established at the outlet of the runner and thereby increase the net head on the turbine. The turbine may be placed above the tail race without any loss of net head and hence turbine may be inspected properly.
2. It converts a large portion of the kinetic energy $\left(\frac{V_2^2}{2g}\right)$ rejected at the outlet of the turbine into useful energy. Without the draft tube the kinetic energy rejected at the turbine will go waste to the tail race.

Hence by using the draft tube, the net head on turbine increases. The turbine develops more power and also the efficiency of the turbine increase.

If a reaction turbine is not fitted with a draft tube, the pressure at the outlet of the runner will be equal to atmospheric pressure. The water from the outlet of the runner will discharge freely into the tail race. The net head on the turbine will be less than that of

a reaction turbine fitted with a draft tube. Also without draft tube the kinetic energy $\left(\frac{V_2^2}{2g}\right)$ rejected at the outlet of the will go water to the tail race.

Types of Draft Tube:

1. Conical Draft Tube
2. Simple Elbow Tubes
3. Moody Spreading tubes
4. Elbow Draft Tubes with Circular inlet and rectangular outlet

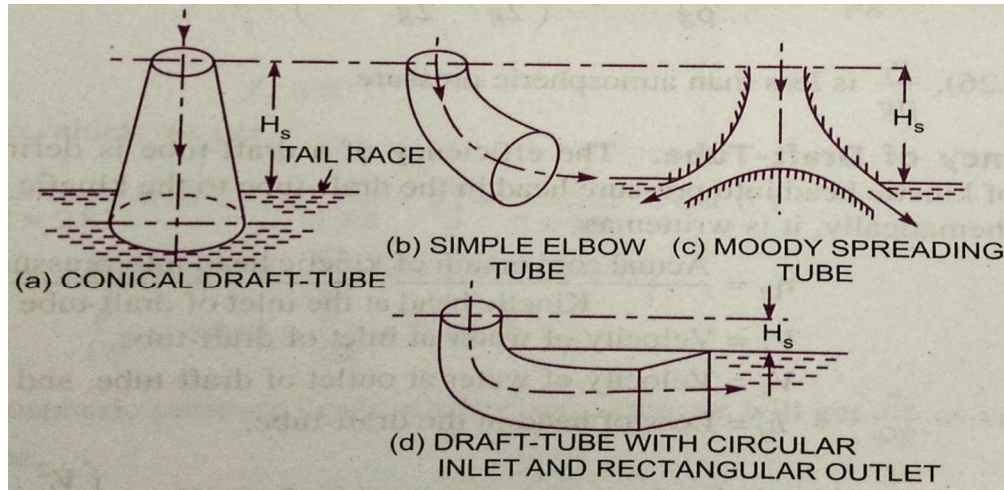

and moody spreading draft tubes are most efficient while simple elbow draft tube and elbow draft tubes with circular inlet and rectangular outlet require less space as compared to other draft tubes.

Draft tube theory: Consider a conical draft tube

H_s = Vertical height of draft tube above tail race

y = Distance of bottom of draft tube from tail race.

Applying Bernoulli's equation to inlet section 1-1 and outlet section 2-2 of the draft tube and taking section 2-2 a datum, we get

$$\frac{p_1}{\rho g} + \frac{V_1^2}{2g} + (H_s + y) = \frac{p_2}{\rho g} + \frac{V_2^2}{2g} + 0 + h_f \quad \text{-----(1)}$$

Where h_f = loss of energy between section 1-1 and 2-2.

But $\frac{p_2}{\rho g}$ = Atmospheric Pressure + $y = \frac{p_a}{\rho g} + y$

Substituting this value of $\frac{p_2}{\rho g}$ in equation (1) we get

$$\frac{p_1}{\rho g} + \frac{V_1^2}{2g} + (H_s + y) = \frac{p_a}{\rho g} + y + \frac{V_2^2}{2g} + h_f$$

$$\frac{p_1}{\rho g} + \frac{V_1^2}{2g} + H_s = \frac{p_a}{\rho g} + \frac{V_2^2}{2g} + h_f$$

$$\frac{p_1}{\rho g} = \frac{p_a}{\rho g} + \frac{V_2^2}{2g} + h_f - \frac{V_1^2}{2g} - H_s$$

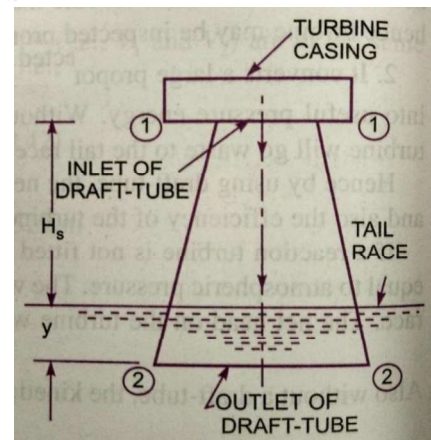

_____ (2)

In equation (2) is less than atmospheric pressure.

$$\frac{p_1}{\rho g} = \frac{p_a}{\rho g} - H_s - \left[\frac{V_1^2}{2g} - \frac{V_2^2}{2g} - h_f \right]$$

Efficiency of Draft Tube: the efficiency of a draft tube is defined as the ratio of actual conversion of kinetic head in to pressure in the draft tube to the kinetic head at the inlet of the draft tube.

$$\eta_d = \frac{\text{Actual conversion of Kinetic head in to Pressure head}}{\text{Kintic head at the inlet of draft tube}}$$

Let V_1 = Velocity of water at inlet of draft tube

V_2 = Velocity of water at outlet of draft tube

h_f = Loss of head in the draft tube

Theoretical conversion of Kinetic head into Pressure head in

$$\text{Draft tube} = \left[\frac{V_1^2}{2g} - \frac{V_2^2}{2g} \right]$$

$$\text{Actual conversion of Kinetic head into pressure head} = \left[\frac{V_1^2}{2g} - \frac{V_2^2}{2g} \right] - h_f$$

Now Efficiency of draft tube

$$\eta_d = \frac{\left[\frac{V_1^2}{2g} - \frac{V_2^2}{2g} \right] - h_f}{\frac{V_1^2}{2g}}$$

PROBLEMS

1. A pelton wheel has a mean bucket speed of 10m/s with a jet of water flowing at the rate of 700lts/sec under a head of 30 m. the buckets deflect the jet through an angle of 160° calculate the power given by the water to the runner and hydraulic efficiency of the turbine? Assume co-efficient of velocity=0.98

Given:

Speed of bucket $u = u_1 = u_2 = 10\text{m/s}$

Discharge $Q = 700\text{lt/sec} = 0.7\text{m}^3/\text{s}$

Head of water $H = 30\text{m}$

Angle deflection = 160°

\therefore Angle $\phi = 180 - 160 = 20^\circ$

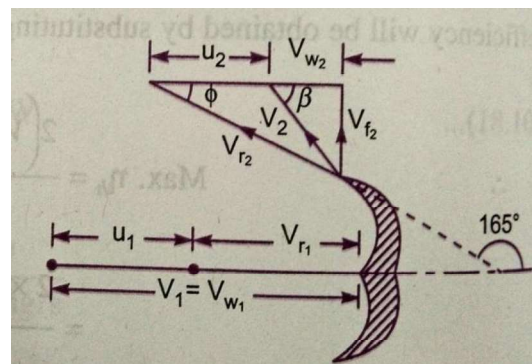

Co-efficient of velocity $C_v = 0.98$

The velocity of jet $V_1 = C_v \sqrt{2gH} = 0.98 \sqrt{2 \times 9.81 \times 30} = 23.77\text{m/s}$

$$V_{r_2} = V_1 - u_1 = 23.77 - 10 = 13.77 \text{ m/s}$$

$$V_{w_2} = V_1 = 23.77 \text{ m/s}$$

From the outlet velocity triangle

$$V_{r_2} = V_{r_2} = \frac{13.77 \text{ m}}{\text{s}}$$

$$\begin{aligned} V_{w_2} &= V_{r_2} \cos \phi - u_2 \\ &= 13.77 \cos 20^\circ - 10 = 2.94 \text{ m/s} \end{aligned}$$

Work done by the jet/sec on the runner is given by equation

$$\begin{aligned} &= \rho a V_1 [V_{w_1} + V_{w_2}] \times u \\ &= 1000 \times 0.7 [23.77 + 2.94] \times 10 \\ &= 186970 \text{ Nm/s} \end{aligned}$$

$$\text{Power given to the turbine} = \frac{186970}{1000} = 186.97 \text{ kW}$$

The hydraulic efficiency of the turbine is given by equation

$$\eta_h = \frac{2[V_{w_1} + V_{w_2}] \times u}{V_1^2} = \frac{2[23.77 + 2.94] \times 10}{23.77 \times 23.77} = 0.9454$$

Or $\quad \quad \quad = 94.54\%$

2. A reaction turbine works at 450rpm under a head of 120m. its diameter at inlet is 120cm and flow area is 0.4 m^2 . The angles made by absolute and relative velocities at inlet are 20° and 60° respectively, with the tangential velocity. Determine

- i) Volume flow rate ii) the power developed
 iii) η_h The hydraulic efficiency. Assume whirl at outlet is zero.

Given: Speed of turbine $N = 450 \text{ rpm}$
 Head $H = 120 \text{ m}$
 Diameter of inlet $D_1 = 120 \text{ cm} = 1.2 \text{ m}$
 Flow area $\pi D_1 \times B_1 = 0.4 \text{ m}^2$

Angle made by absolute velocity $\alpha = 20^\circ$

Angle made by relative velocity $\theta = 60^\circ$

Whirl at outlet $V_{w_2} = 0$

Tangential velocity of the turbine at inlet

$$u_1 = \frac{\pi D_1 N}{60} = \frac{\pi \times 1.2 \times 450}{60} = 28.27 \text{ m/s}$$

From inlet triangle $\tan \alpha = \frac{V_{f_1}}{V_{w_1}}$

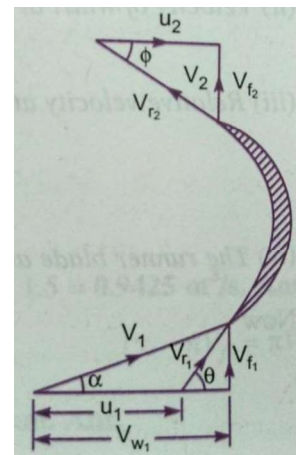

$$\tan 20^\circ = \frac{V_{f1}}{V_{w1}} = 0.364,$$

$$V_{f1} = 0.364V_{w1} \text{-----(1)}$$

Also $\tan \theta = \frac{V_{f1}}{V_{w1} - u_1} = \frac{0.364V_{w1}}{V_{w1} - 28.27} \quad (\because \tan \theta = \tan 60^\circ = 1.732)$

$$1.732 = \frac{0.364V_{w1}}{V_{w1} - 28.27}$$

$$0.364V_{w1} = 1.732(V_{w1} - 28.27)$$

$$0.364V_{w1} = 1.732V_{w1} - 28.27 \times 1.732$$

$$V_{w1}(1.732 - 0.364) = 48.96$$

$$V_{w1} = \frac{48.96}{1.732 - 0.364} = 35.79 \text{ m/s}$$

From equation (1) $V_{f1} = 0.364V_{w1} = 0.364 \times 35.79 = 13.027 \text{ m/s}$

i) Volume flow rate is given by equation as $Q = \pi D_1 B_1 V_{f1}$

$$Q = 0.4 \times 13.027 = 5.211 \text{ m}^3/\text{sec} \quad (\because \pi D_1 B_1 = 0.4 \text{ m}^2)$$

ii) Work done per second on the turbine is given by equation

$$= \rho Q [V_{w1} \times u_1]$$

$$= 1000 \times 5.211 [35.79 \times 28.27] = 5272.402 \text{ Nm/s}$$

Power developed in kW = $\frac{\text{work done per sec}}{1000} = \frac{5272.402}{1000} = 5.272 \text{ kW}$

iii) The hydraulic efficiency is given by equation

$$\eta_h = \frac{V_{w1} \times u_1}{g \times H} = \frac{35.79 \times 28.27}{9.81 \times 120} = 0.8595$$

$$= 85.95\%$$

3. The internal and external diameters of an outward flow reaction turbine are 2m and 2.75m respectively. The turbine is running at 250rpm and the rate of flow of water through the turbine is 5m³/s. the width of the runner is constant at inlet and outlet is equal to 250mm. the head on the turbine is 150m. Neglecting the thickness of the vanes and taking discharge radial at outlet, determine:

i) Vane angle at inlet and outlet

ii) velocity of flow inlet and outlet

Given: Internal diameter $D_1=2\text{m}$
 External diameter $D_2=2.75\text{m}$
 Speed of turbine $N=250\text{rpm}$
 Discharge $Q=5\text{m}^3/\text{s}$

Width at inlet and outlet $B_1=B_2=250\text{mm}=0.25\text{m}$

Head $H = 150\text{m}$

Discharge at outlet = radial

$$\therefore V_{w2} = 0 \text{ and } V_{f2} = V_2$$

The tangential velocity of turbine at inlet and outlet

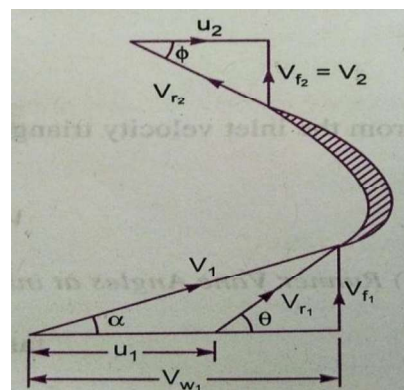

$$u_1 = \frac{\pi D_1 N}{60} = \frac{\pi \times 2 \times 250}{60} = 26.18 \text{ m/s}$$

$$u_2 = \frac{\pi D_2 N}{60} = \frac{\pi \times 2.75 \times 250}{60} = 36 \text{ m/s}$$

The discharge through the turbine is given by

$$V_{f2} = \frac{Q}{\pi D_1 B_1} = \frac{5}{\pi \times 2.75 \times 0.25} = 2.315 \text{ m/s}$$

Using equation $H - \frac{V_2^2}{2g} = \frac{V_{w1} u_1}{g}$ ($\because V_{w2} = 0$)

But for radial discharge $V_2 = V_{f2} = 2.315 \text{ m/s}$

$$150 - \frac{(2.315)^2}{2 \times 9.81} = \frac{V_{w1} \times 26.18}{9.81} \quad \text{Or} \quad 149.73 = \frac{V_{w1} \times 26.18}{9.81}$$

$$V_{w1} = \frac{149.73 \times 9.81}{26.18} = 56.1 \text{ m/s}$$

i) Vane angle at inlet and outlet

From the inlet velocity triangle $\tan \theta = \frac{V_{f1}}{V_{w1} - u_1} = \frac{3.183}{56.1 - 26.18} = 0.1064$

$$\therefore \theta = \tan^{-1} 0.1064 = 6.072^\circ \quad \text{or} \quad 6^\circ 4.32'$$

From outlet velocity triangle $\tan \theta = \frac{V_{f2}}{u_2} = \frac{2.315}{36} = 0.0643$

$$\therefore \theta = \tan^{-1}(0.0643) = 3.68^\circ \quad \text{or} \quad 3^\circ 40.8'$$

ii) Velocity of flow at inlet and outlet

$$V_{f1} = 3.183 \text{ m/s} \quad \text{and} \quad V_{f2} = 2.315 \text{ m/s}$$

4. A Francis turbine with an overall efficiency of 75% is required to produce 148.25kW power. It is working under a head of 7.62m. The peripheral velocity = $0.26 \sqrt{2gh}$ and the radial velocity of flow at inlet is $0.96 \sqrt{2gh}$. The wheel runs at 150rpm and the hydraulic losses in the turbine are 22% of the available energy. Assuming radial discharge determine

i) The guide blade angle. ii) The wheel vane angle at inlet

iii) The diameter of the wheel at inlet, and iv) Width of the wheel at inlet.

Given: Overall efficiency $\eta_o = 75\% = 0.75$

Head $H = 7.62 \text{ m}$

Power Produced S.P. = 148.25kW

Speed $N = 150 \text{ rpm}$

Hydraulic losses = 22% of energy

Peripheral velocity $u_1 = 0.26 \sqrt{2gh} = 0.26 \sqrt{2 \times 9.81 \times 7.62} = 3.179 \text{ m/s}$

Discharge at outlet = Radial

$$V_{w_2} = 0 \quad V_{f_2} = V_2$$

The hydraulic efficiency

But

i) The guide blade angle i.e. From inlet velocity triangle

ii) The wheel angle at inlet

iii) The diameter of wheel at inlet (D_1)

Using relation

$$u_1 = \frac{\pi D_1 N}{60}$$

$$D_1 = \frac{60 \times u_1}{\pi \times N} = \frac{60 \times 3.179}{\pi \times 150} = 0.4047m$$

iv) Width of the wheel at inlet (B_1)

$$\eta_0 = \frac{SP}{WP} = \frac{148.25}{WP}$$

But

$$WP = \frac{W \times H}{1000} = \frac{\rho \times g \times Q \times H}{1000} = \frac{1000 \times 9.81 \times Q \times 7.62}{1000}$$

$$\eta_0 = \frac{148.25 \times 1000}{1000 \times 9.81 \times Q \times 7.62}$$

$$Q = \frac{148.25 \times 1000}{1000 \times 9.81 \times 7.62 \times \eta_0} = \frac{148.25 \times 1000}{1000 \times 9.81 \times 7.62 \times 0.75} = 2.644m^3/s \quad (\because \eta_0 = 75\%)$$

Using equation

$$Q = \pi D_1 B_1 \times V_{f_2}$$

$$2.644 = \pi \times 0.4047 \times B_1 \times 11.738$$

$$B_1 = \frac{2.644}{\pi \times 0.4047 \times 11.738} = 0.177m$$

5. A Kaplan turbine runner is to be designed to develop 7357.5kW shaft power. The net available head is 5.50m. Assume that the speed ratio is 2.09 and flow ratio is 0.68 and the overall efficiency is 60%. The diameter of boss is $\frac{1}{3}$ of the diameter of runner. Find the diameter of the runner, its speed and specific speed.

Given: Shaft power $P = 7357.5kW$

Head $H = 5.5m$

Speed ratio $= \frac{u_1}{\sqrt{2gH}} = 2.09$

$$\therefore u_1 = 2.09 \times \sqrt{2 \times 9.81 \times 5.5} = 21.71m/s$$

Flow ratio $= \frac{V_{f_2}}{\sqrt{2gH}} = 0.68$

$$\therefore V_{f_2} = 0.68 \times \sqrt{2 \times 9.81 \times 5.5} = 7.064 \text{ m/s}$$

Overall Efficiency

$$\eta_0 = 60\% = 0.60$$

Diameter of boss

$$D_b = \frac{1}{3} \times D_0$$

Using the relation

$$\eta_0 = \frac{\text{Shaft power}}{\text{water power}} = \frac{7357.5}{\frac{\rho g Q H}{1000}}$$

$$0.60 = \frac{7357.5 \times 1000}{1000 \times 9.81 \times Q \times 5.5}$$

Discharge

$$Q = \frac{7357.5 \times 1000}{1000 \times 9.81 \times 5.5 \times 0.60} = 227.27 \text{ m}^3/\text{s}$$

Using equation for discharge

$$Q = \frac{\pi}{4} [D_0^2 - D_b^2] \times V_{f_2}$$

$$227.27 = \frac{\pi}{4} \left[D_0^2 - \left(\frac{D_0}{3} \right)^2 \right] \times V_{f_2}$$

$$227.27 = \frac{\pi}{4} \times \frac{8}{9} D_0^2 \times 7.064$$

$$D_0^2 = 227.27 \times \frac{4}{\pi} \times \frac{9}{8} \times \frac{1}{7.064}$$

$$D_0 = 6.788 \text{ m}$$

$$D_b = \frac{1}{3} D_0 = \frac{6.788}{3} = 2.262 \text{ m}$$

Using the relation

$$u_2 = \frac{\pi D_0 N}{60}$$

$$N = \frac{60 \times u_1}{\pi D_0} = \frac{60 \times 21.71}{\pi \times 6.788} = 61.08 \text{ rpm}$$

($\because u_1 = u_2$) The specific speed

$$N_s = \frac{N \sqrt{P}}{H^{5/4}} = \frac{61.08 \times \sqrt{7357.5}}{(5.5)^{5/4}} = 622 \text{ rpm}$$

Geometric similarity

The geometric similarity must exist between the model and its proto type. the ratio of all corresponding linear dimensions in the model and its proto type are equal.

Let L_m = length of model

b_m = Breadth of model

D_m = Diameter of model

A_m = Area of model

V_m = Volume of model

And L_p, b_p, D_p, A_p, V_p = Corresponding values of the proto type.

For geometrical similarity between model and prototype, we must have the relation,

$$\frac{L_p}{L_m} = \frac{b_p}{b_m} = \frac{D_p}{D_m} = L_r$$

Where L_r is called scale ratio.

For area's ratio and volume's ratio the relation should be,

$$\frac{A_p}{A_m} = \frac{L_p \times b_p}{L_m \times b_m} = L_r \times L_r = L_r^2$$

$$\frac{V_p}{V_m} = \left(\frac{L_p}{L_m}\right)^3 = \left(\frac{b_p}{b_m}\right)^3 = \left(\frac{D_p}{D_m}\right)^3 = L_r^3$$

Performance of Hydraulic Turbines

In order to predict the behavior of a turbine working under varying conditions of head, speed, output and gate opening , the results are expressed in terms of quantities which may be obtained when the head on the turbine is reduced to unity. The conditions of the turbine under unit head are such that the efficiency of the turbine remains unaffected. The three important unit quantities are:

1. Unit speed,
2. Unit discharge, and
3. Unit power

1. Unit Speed: it is defined as the speed of a turbine working under a unit head. It is denoted by ' N_u '. The expression of unit speed (N_u) is obtained as:

Let N = Speed of the turbine under a head H

H = Head under which a turbine is working

u = Tangential velocity.

The tangential velocity, absolute velocity of water and head on turbine are related as:

$$u \propto V \quad \text{Where } V \propto \sqrt{H}$$

$$\propto \sqrt{H} \quad \text{_____ (1)}$$

Also tangential velocity (u) is given by

$$u = \frac{\pi DN}{60} \quad \text{Where } D = \text{Diameter of turbine.}$$

For a given turbine, the diameter (D) is constant

$$u \propto N \quad \text{Or } N \propto u \quad \text{Or } N \propto \sqrt{H} \quad (\because \text{From (1), } u \propto \sqrt{H})$$

$$\therefore N = K_1 \sqrt{H} \quad \text{_____ (2) \quad Where } K_1 \text{ is constant of proportionality.}$$

If head on the turbine becomes unity, the speed becomes unit speed or

$$\text{When } H = 1, N = N_u$$

Substituting these values in equation (2), we get

$$N_u = K_1 \sqrt{1.0} = K_1$$

Substituting the value of K_1 in equation (2)

$$N = N_u \sqrt{H} \quad \text{or } N_u = \frac{N}{\sqrt{H}} \quad \text{_____ (I)}$$

2. Unit Discharge: It is defined as the discharge passing through a turbine, which is working under a unit head (i.e. 1 m). It is denoted by ' Q_u ' the expression for unit discharge is given as:

Let H = head of water on the turbine

Q = Discharge passing through turbine when head is H on the turbine.

a = Area of flow of water

The discharge passing through a given turbine under a head 'H' is given by,

$$Q = \text{Area of flow} \times \text{Velocity}$$

But for a turbine, area of flow is constant and velocity is proportional to \sqrt{H}

$$Q \propto \text{velocity} \propto \sqrt{H}$$

Or

$$Q = K_2 \sqrt{H} \quad \text{_____ (3)}$$

Where K_2 is constant of proportionality

If $H = 1, Q = Q_u$ (By definition)

Substituting these values in equation (3) we get

$$Q_u = K_2 \sqrt{1.0} = K_2$$

Substituting the value of K_2 in equation (3) we get

$$Q = Q_u \sqrt{H}$$

$$Q_u = \frac{Q}{\sqrt{H}} \quad \text{_____ (II)}$$

3. Unit Power: It is defined as the power developed by a turbine working under a unit head (i.e. under a head of 1m). It is denoted by ' P_u '. The expression for unit power is obtained as:

Let H = Head of water on the turbine

P = Power developed by the turbine under a head of H

Q = Discharge through turbine under a head H

The overall efficiency (η_0) is given as

$$\eta_0 = \frac{\text{Power developed}}{\text{Water power}} = \frac{P}{\frac{\rho g Q H}{1000}}$$

$$P = \eta_0 \times \frac{\rho g Q h}{1000}$$

$$\propto Q \times H \propto \sqrt{H} \times H \quad (\because Q \propto \sqrt{H})$$

$$\propto H^{\frac{3}{2}}$$

$$P = K_3 H^{3/2} \quad \text{_____ (4) Where } K_3 \text{ is a constant of proportionality}$$

When $H=1 \text{ m}, P = P_u$

$$\therefore P_u = K_3 (1)^{3/2} = K_3$$

Substituting the value of K_3 in equation (4) we get

$$P = P_u H^{\frac{3}{2}}$$

$$P_u = \frac{P}{H^{3/2}} \quad \text{_____ (III)}$$

Use of Unit Quantities (N_u, Q_u, P_u):

If a turbine is working under different heads, the behaviour of the turbine can be easily known from the values of the unit quantities i.e. from the value of unit speed, unit discharge and unit power.

Let H_1, H_2, H_3, \dots are the heads under which a turbine works,
 N_1, N_2, N_3, \dots are the corresponding speeds,
 Q_1, Q_2, Q_3, \dots are the discharge and
 P_1, P_2, P_3, \dots are the power developed by the turbine.

Using equation I, II, III respectively,

$$\left. \begin{aligned} N_u &= \frac{N_1}{\sqrt{H_1}} = \frac{N_2}{\sqrt{H_2}} = \frac{N_3}{\sqrt{H_3}} \\ Q_u &= \frac{Q_1}{\sqrt{H_1}} = \frac{Q_2}{\sqrt{H_2}} = \frac{Q_3}{\sqrt{H_3}} \\ P_u &= \frac{P_1}{H_1^{3/2}} = \frac{P_2}{H_2^{3/2}} = \frac{P_3}{H_3^{3/2}} \end{aligned} \right\} \text{-----(IV)}$$

Hence, if the speed, discharge and power developed by a turbine under a head are known, then by using equation (IV) the speed, discharge, power developed by the same turbine a different head can be obtained easily.

CHARACTERISTIC CURVES OF HYDRAULIC TURBINES:

Characteristic curves of a hydraulic turbine are the curves, with the help of which the exact behaviour and performance of the turbine under different working conditions can be known. These curves are plotted from the results of the tests performed on the turbine under different working conditions.

The important parameters which are varied during a test on turbine are:

- | | | |
|--------------|--|------------------|
| 1) Speed (N) | 2) Head (H) | 3) Discharge (Q) |
| 4) Power (P) | 5) Overall Efficiency (η_o) and | 6) Gate opening. |

Out of the above six parameters, three parameters namely speed (N), Head (H) and discharge (Q) are independent parameters.

Out of the three independent parameters, (N, H, Q) one of the parameter is kept constant (say H) and the variation of other two parameters with respect to any one of the remaining two independent variables (say N and Q) are plotted and various curves are obtained. These curves are called characteristic curves. The following are the important characteristic curves of a turbine.

1. Main Characteristic Curves or Constant Head Curves.
2. Operating Characteristic Curves or Constant Speed Curves.
3. Muschel Curves or Constant Efficiency Curves.

1. Main Characteristic Curves or Constant Head Curves:

These curves are obtained by maintaining a constant head and a constant gate opening (G.O.) on the turbine. The speed of the turbine is varied by changing the load on the turbine. For each value of the speed, the corresponding values of the power (P) and discharge (Q) are obtained. Then the overall efficiency (η_0) for each value of the speed is calculated. From these readings the values of unit speed (N_u), unit power (P_u) and unit discharge (Q_u) are determined. Taking N_u as abscissa, the values of Q_u , P_u , P and η_0 are plotted. By changing the gate opening, the values of Q_u and N_u are determined and taking N_u as abscissa, the values of Q_u , P_u and η_0 are plotted.

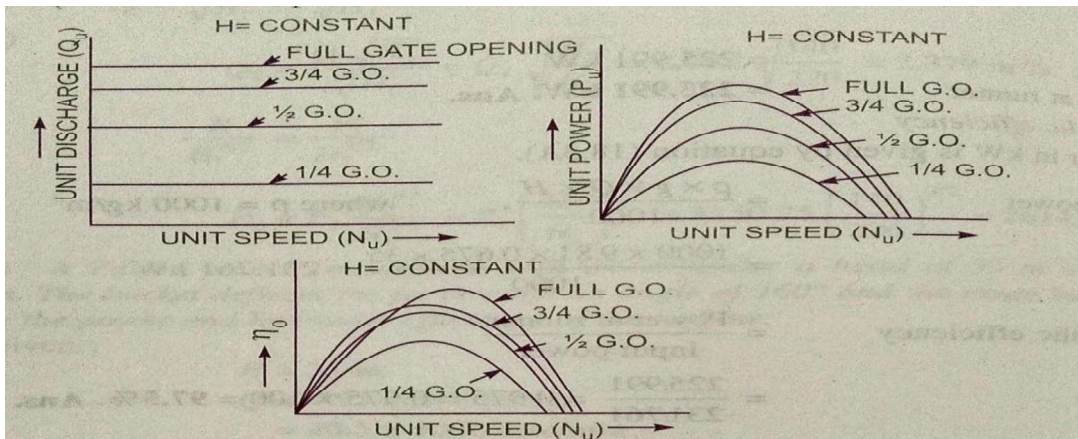
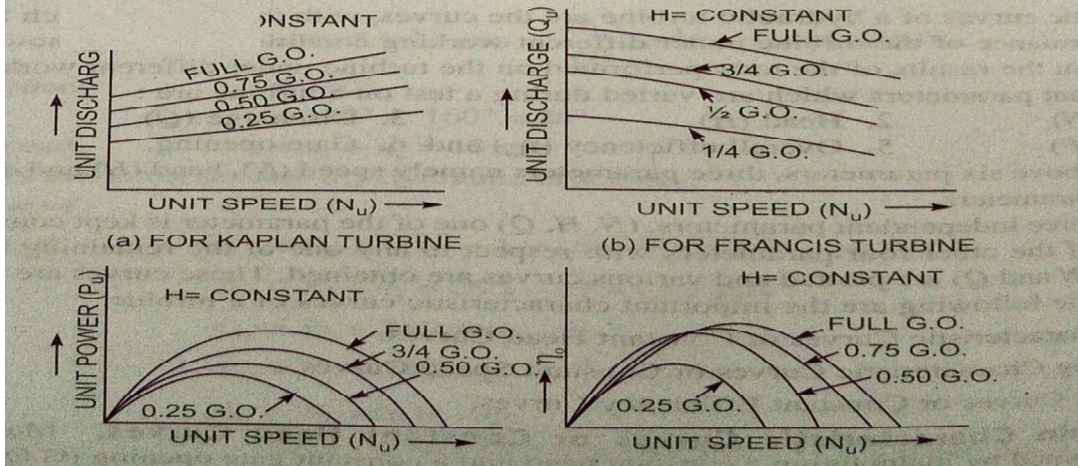
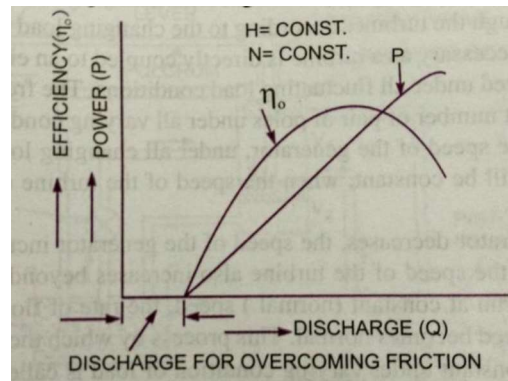

Fig. 18.35 Main characteristic curves for a Pelton wheel.



2. Operating Characteristic Curves or Constant Speed Curves:

These curves are plotted when the speed on the turbine is constant. In case turbines, the head is generally constant. As already discussed there are three independent parameters namely N , H and Q . For operating characteristics N and H are constant and hence the variation of power and the efficiency with respect to discharge Q are plotted. The power curve for the turbine shall not pass through the origin, because certain amount of discharge is needed to produce power to



overcome initial friction. Hence the power and efficiency curves will be slightly away from the origin on the x-axis, as to overcome initial friction certain amount of discharge will be required.

3. Constant Efficiency Curves or Muschel Curves or Iso - Efficiency Curves:

These curves are obtained from the speed vs. efficiency and speed vs. discharge curves for different gate openings. For a given efficiency from the N_u vs. η_0 curves there are two speeds. From the N_u vs. Q_u curves, corresponding to two values of speeds there are two values of discharge. Hence for a given efficiency there are two values of discharge for a particular gate opening. This means for a given efficiency there are two values of speeds and two values of discharge for a given gate opening. If the efficiency is maximum there is only one value. These two values of speed and two values of discharge. Corresponding to a particular gate opening are plotted. The procedure is repeated for different gate openings and the curves Q vs. N are plotted. The points having the same efficiencies are joined. The curves having the same efficiency

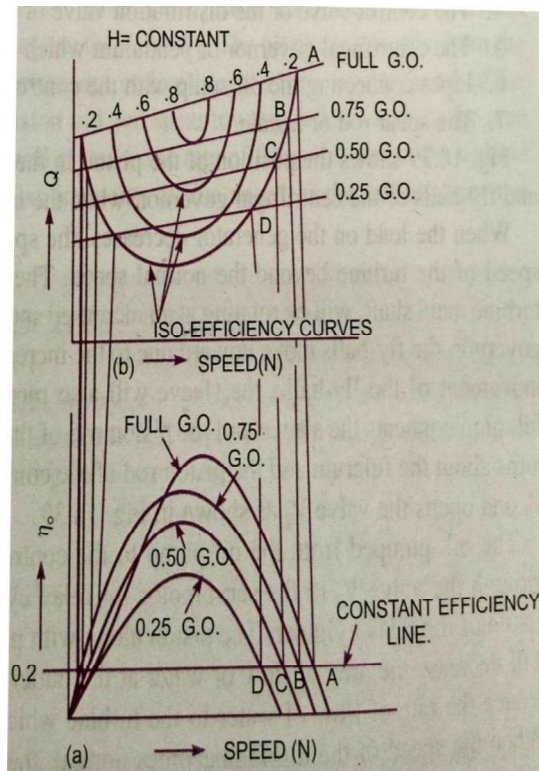

are called Iso-efficiency curves. These curves are helpful for determining the zone of constant efficiency and for predicating the performance of the turbine at various efficiencies.

For plotting the Iso-efficiency curves, horizontal lines representing the same efficiency are drawn on the $\eta_0 \sim$ speed curves. The points at which these lines cut the efficiency curves at various gate opening are transferred to the corresponding $Q \sim$ speed curves. The points having the same efficiency are then joined by smooth curves. These smooth curves represent the Iso-efficiency curves.

Cavitation : Cavitation is defined as the phenomenon of formation of vapour bubbles of a flowing liquid in a region, where the pressure of the liquid falls below its vapour pressure and the sudden collapsing of these vapour bubbles in a region of higher pressure. When the vapour bubbles collapse, a very high pressure is created. The metallic surfaces, above which these vapour bubbles collapse, is subjected to these high pressures, which cause pitting action on the surface. Thus cavities are formed on the metallic surface and also considerable noise and vibrations are produced.

Cavitation includes formation of vapour bubbles of the flowing liquid and collapsing of the vapour bubbles. Formation of vapour bubbles of the flowing liquid take place only whenever the pressure in any region falls below vapour pressure. When the pressure of the flowing liquid is less than its vapour pressure, the liquid starts boiling and the vapour bubbles are formed. These vapour bubbles are carried along with the flowing liquid to higher pressure zones, where these vapour condense and the bubbles collapse. Due to sudden collapsing of the bubbles on the metallic surface, high pressure is produced and metallic surfaces are subjected to high local stress. Thus the surfaces are damaged.

Precaution against Cavitation: The following are the Precaution against cavitation

- i. The pressure of the flowing liquid in any part of the hydraulic system should not be allowed to fall below its vapour pressure. If the flowing liquid is water, then the absolute pressure head should not be below 2.5m of water.
- ii. The special materials or coatings such as Aluminum-bronze and stainless steel, which are cavitation resistant materials, should be used.

Effects of Cavitation: the following are the effects of cavitation.

- i. The metallic surfaces are damaged and cavities are formed on the surfaces.
- ii. Due to sudden collapse of vapour bubbles, considerable noise and vibrations are produced.
- iii. The efficiency of a turbine decreases due to cavitation. Due to pitting action, the surface of the turbine blades becomes rough and the force exerted by the water on the turbine blades decreases. Hence, the work done by water or output horse power becomes less and efficiency decreases.

Hydraulic Machines Subjected to Cavitation: The hydraulic machines subjected to Cavitation are reaction turbine and centrifugal pumps.

Cavitation in Turbines: in turbines, only reaction turbines are subjected to cavitation. In reaction turbines the cavitation may occur at the outlet of the runner or at the inlet of the draft tube where the pressure is considerably reduced. (i.e. which may be below vapour pressure of the liquid flowing through the turbine) Due to cavitation, the metal of the runner vanes and draft tube is gradually eaten away, which results in lowering the efficiency of the turbine. Hence the cavitation in a reaction turbine can be noted by a sudden drop in efficiency. In order to determine whether cavitation will occur in any portion of a reaction turbine, the critical value of Thoma's cavitation factors σ is calculated.

$$\sigma = \frac{H_b - H_s}{H} = \frac{(H_{atm} - H_v) - H_s}{H} ,$$

Where H_b = Barometric pressure head in m of water,

H_{atm} = Atmospheric pressure head in m of water,

H_v = Vapour pressure head in m of water,

H_s =

Department of Mechanical Engineering, MRCET

Suction pressure at the outlet of reaction turbine in m of water or height of turbine runner above the tail water surface,

H = Net head on the turbine in m.

Surge Tank:

When the load on the generator decreases, the governor reduces the rate of flow of water striking the runner to maintain constant speed for the runner. The sudden reaction of rate of flow in the penstock may lead to water hammer in pipe due to which the pipe may burst. When the load on the generator increases the turbine requires more water. Surge tanks and fore bays are usually employed to meet the above requirements. Surge tanks are employed in case of high head and medium head hydro power plants where the penstock is very long and fore bays are suitable for medium and low head hydro power plants where the length of penstock is short.

An ordinary surge tank is a cylindrical open topped storage reservoir, which is connected to the penstock at a point as close as possible to the turbine. The upper lip of the tank is kept well above the maximum water level in the supply reservoir. When the load on the turbine is steady and normal and there are no velocity variations in the pipe line there will be normal pressure gradient oaa_1 . The water surface in the surge tank will be lower than the reservoir surface by an amount equal to friction head loss in the pipe connecting reservoir and surge tank. When the load on the generator is reduced, the turbine gates are closed and the water moving towards the turbine has to move back ward. The rejected water is then stored in the surge tank, raising the pressure gradient. The retarding head so built up in the surge tank reduces the velocity of flow in the pipe line corresponding to the reduced discharge required by the turbine.

When the load on the generator increases the governor opens the turbine gates to increase the rate of flow entering the runner. The increased demand of water by the turbine is partly met by the water stored in the surge tank. As such the water level in the surge tank falls and falling pressure gradient is developed. In other words, the surge tank develops an accelerating head which increases the velocity of flow in the pipe line to a value corresponding to the increased discharge required by the turbine.

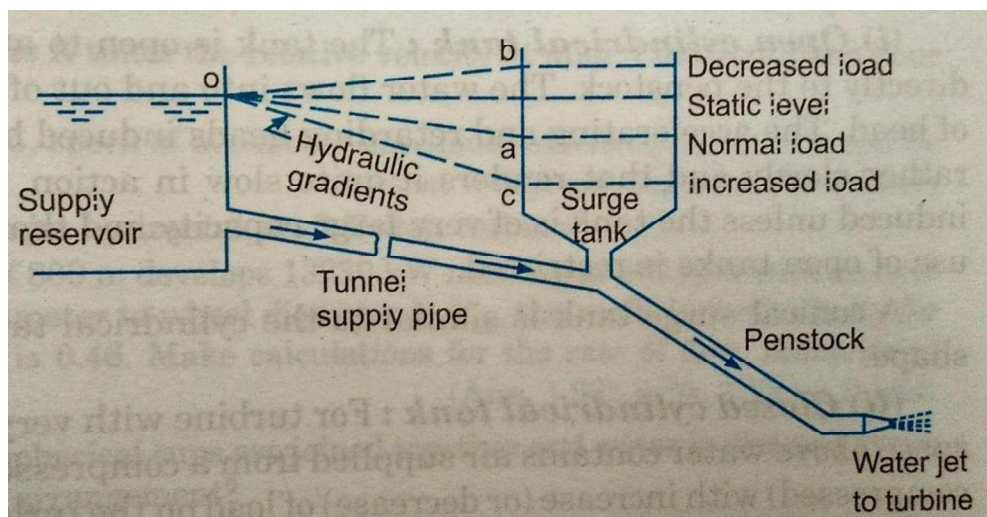

Water Hammer:

Consider a long pipe AB, connected at one end to a tank containing water at a height of H from the centre of the pipe. At the other end of the pipe, a valve to regulate the flow of water is provided. When the valve is completely open, the water is flowing with a

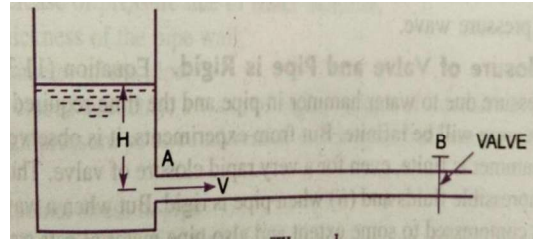

velocity, V in the pipe. If now the valve is suddenly closed, the momentum of the flowing water will be destroyed and consequently a wave of high pressure will be set up. This wave of high pressure will be transmitted along the pipe with a velocity equal to the velocity of sound wave and may create noise called knocking. Also this wave of high pressure has the effect of hammering action on the walls of the pipe and hence it is known as water hammer.

The pressure rise due to water hammer depends up on:

1. Velocity of flow of water in pipe.
2. The length of pipe.
3. Time taken to close the valve.
4. Elastic properties of the material of the pipe.

The following cases of water hammer in pipes will be considered.

1. Gradual closure of valve
2. Sudden closure of valve considering pipe in rigid
3. Sudden closer of valve considering pipe elastic.

1. Gradual Closure of Valve:

$$\text{Mass of water in pipe} = \rho \times \text{volume of water} = \rho \times A \times L$$

Where A = Area of cross-section of the pipe

L = Length of pipe

The valve is closed gradually in time „T“ seconds and hence the water is brought from initial velocity V to zero velocity in time seconds.

$$\therefore \text{Retardation of water} = \frac{\text{change of velocity}}{\text{Time}} = \frac{V-0}{T} = \frac{V}{T}$$

$$\therefore \text{Retarding force} = \text{Mass} \times \text{Retardation} = \rho AL \times \frac{V}{T} \quad \text{-----(1)}$$

If p is the intensity of pressure wave produced due to closure of the valve, the force due to pressure wave

$$= p \times \text{Area of pipe} = p \times A \quad \text{-----(2)}$$

Equating the two forces given by equation (1) & (2)

$$\rho AL \times \frac{V}{T} = p \times A$$

$$p = \frac{\rho LV}{T}$$

Head of pressure $H = \frac{p}{\rho g} = \frac{\rho LV}{\rho g \times T} = \frac{LV}{gT}$

i) The valve closure is said to be gradual if $T > \frac{2L}{C}$

Where T = Time in sec, C= Velocity of Pressure wave

ii) The valve closure is said to be sudden if $T < \frac{2L}{C}$

Where C = Velocity of Pressure Wave

2) Sudden Closure of Valve and Pipe is Rigid:

In sudden closure of valve $T=0$, the increase in pressure will be infinite when wave of high pressure is created the liquid gets compressed to some extent and pipe material gets stretched. For a sudden closure of valve, the valve of T is very small and hence a wave of high pressure is created.

When the valve is closed suddenly, the kinetic energy of flowing water is converted in to strain energy of water if the effect of friction is neglected and pipe wall is assumed to be rigid.

$$\begin{aligned}\therefore \text{loss of kinetic energy} &= \frac{1}{2} \times \text{mass of water in pipe} \times V^2 \\ &= \frac{1}{2} \times \rho AL \times V^2\end{aligned}$$

$$\text{Gain of strain energy} = \frac{1}{2} \left[\frac{p^2}{K} \right] \times \text{volum} = \frac{1}{2} \frac{p^2}{K} \times AL$$

Equating loss of Kinetic energy to gain of strain energy

$$\frac{1}{2} \times \rho AL \times V^2 = \frac{1}{2} \frac{p^2}{K} \times AL$$

$$p^2 = \frac{1}{2} \times \rho AL \times V^2 \times \frac{2K}{AL} = \rho KV^2$$

$$p = \sqrt{\rho KV^2} = V\sqrt{K\rho} = V\sqrt{\frac{K\rho^2}{\rho}}$$

$$p = \rho V \sqrt{\frac{K}{\rho}} \quad \left(\because \sqrt{\frac{K}{\rho}} = C \right)$$

$$p = \rho V \times C$$

Where C = velocity of pressure wave.

UNIT-5

CENTRIFUGAL PUMPS

The hydraulic machines which convert the mechanical energy in to hydraulic energy are called pumps. The hydraulic energy is in the form of pressure energy. If the mechanical energy is converted in to pressure energy by means of centrifugal force acting on the fluid, the hydraulic machine is called centrifugal pump.

The centrifugal pump acts as a reversed of an inward radial flow reaction turbine. This means that the flow in centrifugal pumps is in the radial outward directions. The centrifugal pump works on the principle of forced vortex flow which means that when a certain mass of liquid is rotated by an external torque, the rise in pressure head of the rotating liquid takes place. The rise in pressure head at any point of the rotating liquid is proportional to the square of tangential velocity of the liquid at that point. (i.e. rise in pressure head = $\frac{v^2}{2g}$ or $\frac{r^2 \omega^2}{2g}$). Thus the outlet of the impeller, where radius is more, the rise in pressure head will be more and the liquid will be discharged at the outlet with a high pressure head. Due to this high pressure head, the liquid can be lifted to a high level.

The following are the main parts of a centrifugal pump.

1) Impeller. 2) Casing. 3) Suction pipe with foot valve and a strainer 4) Delivery pipe.

1. Impeller: The rotating part of a centrifugal pump is called impeller. It consists of a series of backward curved vanes. The impeller is mounted on a shaft which is connected to the shaft of an electric motor.

2. Casing: the casing of a centrifugal pump is similar to the casing of a reaction turbine. It is an air tight passage surrounding the impeller and is designed in such a way that the kinetic energy of the water discharged at the outlet of the impeller is converted in to pressure energy before the water leaves the casing and enters the delivery pipe. The following three types of the casing are commonly adopted.

- a) Volute
- b) Vortex
- c) Casing with guide blades

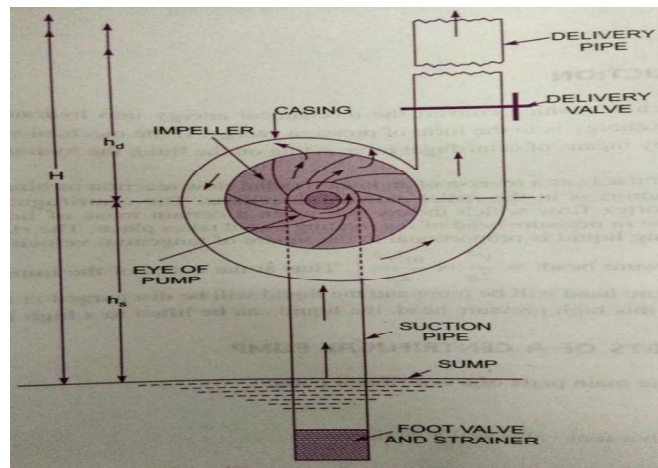

a) **Volute Casing:** It is the casing surrounding the impeller. It is of a spiral type, in which area of flow increases gradually. The increase in area of flow decreases the velocity of flow. The decrease in velocity increases the pressure of the water flowing through the casing. It has been observed that in case of volute casing, the efficiency of the pump increase slightly as a large amount of energy is lost due to the formation of eddies in this type of casing.

b) **Vortex Casing:** If a circular chamber is introduced between the casing and the impeller, the casing is known as vortex casing. By introducing the circular chamber, the loss of energy due to the formation of eddies is reduced to a considerable extent. Thus the efficiency of the pump is more than the efficiency when only volute casing is provided.

c) **Casing with guide blades:** in this type of casing the impeller is surrounded by a series of guide blades mounted on a ring known as diffuser. The guide vanes are designed in which way that the water from the impeller enters the guide vanes without shock.

Also the area of guide vanes increases thus reducing the velocity of flow through guide vanes and consequently increasing the pressure of the water. The water from the guide vanes then pass through the surrounding casing, which is in most of the cases concentric with the impeller.

3. Suction pipe with a foot valve and a strainer: A pipe whose one end is connected to the inlet of the pump and other end dips in to water in a sump is known as suction pipe. A foot valve which is a non-return valve or one-way type of valve is fitted at the lower end of the suction pipe. The foot valve opens only in the upward direction. A strainer is also fitted at the lower end of the suction pipe.

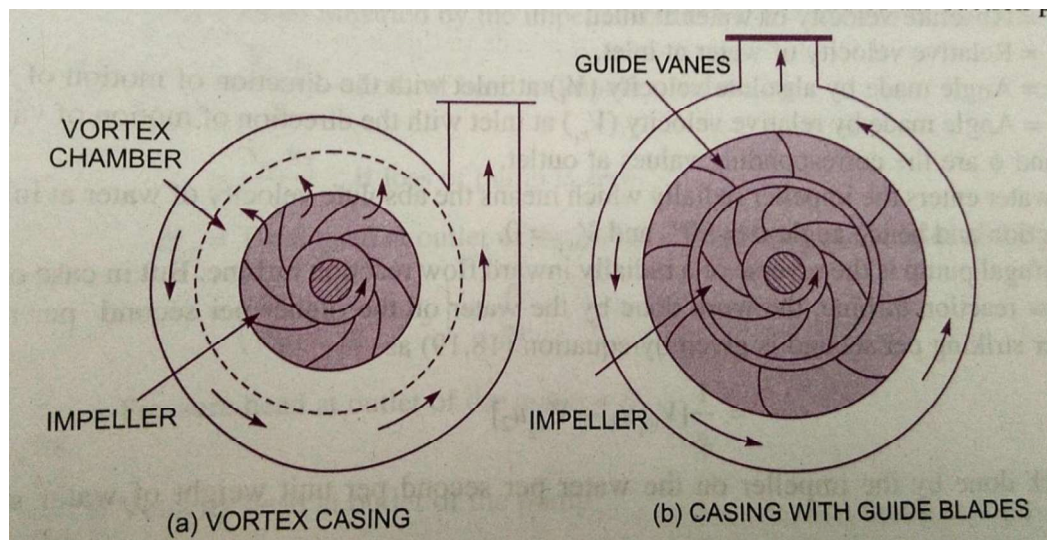

4. Delivery pipe: A pipe whose one end is connected to the outlet of the pump and the other end delivers the water at the required height is known as delivery pipe.

Work done by the centrifugal pump on water:

In the centrifugal pump, work is done by the impeller on the water. The expression for the work done by the impeller on the water is obtained by drawing velocity triangles at inlet and outlet of the impeller in the same way as for a turbine. The water enters the impeller radially at inlet for best efficiency of the pump, which means the absolute velocity of water at inlet makes an angle of 90° with the direction of motion of the impeller at inlet. Hence angle $\alpha = 90^\circ$ and $V_{w1} = 0$ for drawing the velocity triangles the same notations are used as that for turbines.

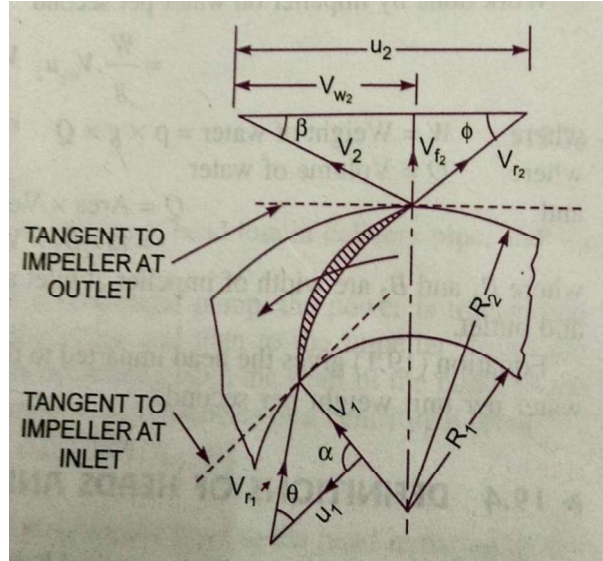

Let $N =$ Speed of the impeller in r.p.m.

$D_1 =$ Diameter of impeller at inlet

$$u_1 = \text{Tangential velocity of impeller at inlet} = \frac{\pi D_1 N}{60}$$

$D_2 =$ Diameter of impeller at outlet

$$u_2 = \text{Tangential velocity of impeller at outlet} = \frac{\pi D_2 N}{60}$$

$V_1 =$ Absolute velocity of water at inlet.

$V_{r1} =$ Relative velocity of water at inlet

$\alpha =$ Angle made by absolute velocity V_1 at inlet with the direction of motion of vane

$\theta =$ Angle made by relative velocity (V_{r1}) at inlet with the direction of motion of vane

And V_2, V_{r2}, β and ϕ are the corresponding values at outlet.

As the water enters the impeller radially which means the absolute velocity of water at inlet is in the radial direction and hence angle $\alpha = 90^\circ$ and $V_{w1} = 0$.

A centrifugal pump is the reverse of a radially inward flow reaction turbine. But in case of a radially inward flow reaction turbine, the work done by the water on the runner per second per unit weight of the water striking per second is given by equation.

$$= -\frac{1}{w_1} u_1 - V_{w2} u_2$$

∴ Work done by the impeller on the water per second per unit weight of water striking/second

= - workdone in case of a turbine

$$= - \frac{1}{g} V_{w_1} u_1 - V_{w_2} u_2$$

$$= - \frac{1}{g} V_{w_2} u_2 - V_{w_1} u_1$$

$$= - \frac{1}{g} V_{w_2} u_2 \quad \text{_____ (1)} \quad \because w_1 = 0$$

Work done by the impeller on water per second

$$= \frac{W}{g} \times V u$$

Where W = Weight of water = $\rho \times g \times Q$

Q = Volume of water

Q = Area \times Velocity of flow

$$= D_1 B_1 \times V_{f_1}$$

$$= \pi D_2 B_2 \times V_{f_2}$$

Where B_1 and B_2 are width of impeller at inlet and outlet and

V_{f_1} And V_{f_2} are velocities of flow at inlet and outlet

Head imparted to the water by the impeller or energy given by impeller to water per unit weight per second

$$= \frac{1}{g} V_{w_2} u_2$$

HEADS OF A CENTRIFUGAL PUMP:

1. Suction Head h : It is the vertical height of the centre line of centrifugal pump, above the water surface in the tank or sump from which water is to be lifted. This height is also called suction lift ' \square_s' '.

2. Delivery Head h : The vertical distance between the centre line of the pump and the water surface in the tank to which water is delivered is known as delivery head. This is denoted by ' \square_d' '.

3. Static Head H : The sum of suction head and delivery head is known as static head ' H_s' '.

$$H_s = \square_s + \square_d$$

4. Manometric Head H : Manometric head is defined as the head against which a centrifugal pump has to work. It is denoted by H .

a) H_m = Head imparted by the impeller to the water – Loss of head in the pump

$$= \frac{V_{w2} u_2}{g} - \text{Loss of head in impeller and casing}$$

$$= \frac{V_{w2} u_2}{g} \dots\dots\dots \text{ If loss of head in pump is zero.}$$

b) H_m = Total head at outlet of pump – Total head at the inlet of the pump

$$= \frac{P_0}{\rho g} + \frac{V_0^2}{2g} + Z_0 - \frac{P_i}{\rho g} + \frac{V_i^2}{2g} + Z_i$$

Where $\frac{P_0}{\rho g}$ = Pressure head at outlet of the pump = $\frac{P}{\rho g}$

$\frac{V_0^2}{2g}$ = Velocity head at outlet of the pump

$$= \text{Velocity head in delivery pipe} = \frac{V_d^2}{2g}$$

Z_0 = Vertical height of the outlet of the pump from datum line, and

$\frac{P}{\rho g}, \frac{V_i^2}{2g}, Z_i$ = Corresponding values of pressure head, velocity head and datum head at the

In let of the pump,

i.e. $\frac{V_s^2}{2g}$ and Z_s respectively.

$$c) H_m = \frac{P}{\rho g} + \frac{V_d^2}{2g} - \frac{P_s}{\rho g} - \frac{V_s^2}{2g} - \frac{f_s}{f_d}$$

Where s = Suction head,

$\frac{P}{\rho g}$ = Delivery head,

$\frac{f_s}{f_d}$ = Frictional head loss in suction pipe,

$\frac{f_d}{f_d}$ = Frictional head loss in delivery pipe

V_d = Velocity of water in delivery pipe.

5. Efficiencies of a Centrifugal Pump: In a centrifugal pump, the power is transmitted from electric motor shaft to pump shaft and then to the impeller. From the impeller, the power is given to the water. Thus the power is decreasing from the shaft of the pump to the impeller and then to the water. The following are the important efficiencies of a centrifugal pump:

- a) Manometric efficiency, η_{man}
- b) Mechanical efficiency, η_m and
- c) Overall efficiency, η_0 .

a) **Manometric Efficiency η_{man} :** The ratio of the Manometric head to the head imparted by the impeller to the water is known as

$$\begin{aligned} \text{Manometric Efficiency } \eta_{man} &= \frac{\text{Manometric Head}}{\text{Head imparted by impeller to water}} \\ &= \frac{H_m}{\frac{V_{w2} u_2}{g}} = \frac{g H_m}{V_{w2} u_2} \end{aligned}$$

The power at the impeller of the pump is more than the power given to the water at outlet of the pump. The ratio of power given to the water at outlet of the pump to the power available at the impeller is known as Manometric efficiency.

The power given to the water at outlet of the pump = $\frac{WH_m}{1000}$ kW

The power at the impeller = $\frac{\text{Work done by impeller per second}}{1000}$ kW

$$\begin{aligned} &= \frac{W}{g} \times \frac{V_{w2} \times u_2}{1000} \text{ kW} \\ \eta_{man} &= \frac{\frac{WH_m}{1000}}{\frac{W}{g} \times \frac{V_{w2} \times u_2}{1000}} = \frac{g \times H_m}{V_{w2} \times u_2} \end{aligned}$$

b) Mechanical Efficiency η : The power at the shaft of the centrifugal pump is more the power available at the impeller of the pump. The ratio of the power available at the impeller to the power at the shaft of the centrifugal pump is known as mechanical efficiency.

$$\eta_m = \frac{\text{Power at the impeller}}{\text{Power at the shaft}}$$

The power at the impeller in kW = $\frac{\text{Work done by impeller per second}}{1000} = \frac{W}{g} \times \frac{V_{w2} \times u_2}{1000}$

$$\eta_m = \frac{\frac{W V_{w2} \times u_2}{g \times 1000}}{S.P.}$$

Where S.P. = Shaft power.

c) Overall Efficiency η : It is defined as the ratio of power output of the pump to the power input to the pump.

The power output of the pump in kW = $\frac{\text{Weight of water lifted}}{\times H_m} = \frac{WH_m}{1000}$

The power input to the pump = $\frac{\text{Power supplied by the electric motor}}{1000}$
= S.P. Of the pump

$$\therefore \eta_0 = \frac{\frac{WH_m}{1000}}{S.P.}$$

$$\eta_0 = \eta_{man} \times \eta_m$$

SPECIFIC SPEED OF A CENTRIFUGAL PUMP N_s :

The specific speed of a centrifugal pump is defined as the speed of a geometrically similar pump, which would deliver one cubic meter of liquid per second against a head of one meter. It is denoted by ' N_s '.

The discharge Q for a centrifugal pump is given by the relation

$$\begin{aligned} Q &= \text{Area} \times \text{Velocity of flow} \\ &= D \times B \times V_f \quad \text{Or} \quad Q \propto D \times B \times V_f \quad (1) \end{aligned}$$

Where D = Diameter of the impeller of the pump and

B = Width of the impeller

We know that $B \propto D$

From equation (1) we have $\propto D^2 \times V_f$ (2)

We also know that the tangential velocity is given by

$$u = \frac{\pi DN}{60} \propto DN \quad (3)$$

Now the tangential velocity (u) and velocity of flow V_f are related to Manometric head H_m as

$$\propto V_f \propto \overline{H_m} \quad (4)$$

Substituting the value of (u) in equation (3), we get

$$\overline{H_m} \propto DN \quad \text{Or} \quad D \propto \frac{\overline{H_m}}{N}$$

Substituting the values of D in equation (2)

$$\begin{aligned} Q &\propto \frac{H_m}{N^2} \times V_f \\ &\propto \frac{H_m}{N^2} \times \frac{H_m}{m} \quad \because \text{From eq 4 } V_f \propto \frac{H_m}{m} \\ &\propto \frac{H_m^{3/2}}{N^2} \\ &= K \frac{H_m^{3/2}}{N^2} \quad (5) \end{aligned}$$

Where K is a constant of proportionality

If $H_m = 1m$ and $Q = 1m^3/sec$ N becomes N_s

Substituting these values in equation (5), we get

$$1 = K \frac{1^{3/2}}{N_s^2} = \frac{K}{N_s^2}$$

\therefore

$$K = N_s^2$$

Substituting the value of K in equation (5), we get

$$Q = N_s^2 \frac{H_m^{3/2}}{N^2} \quad \text{or} \quad N_s^2 = \frac{N^2 Q}{H_m^{3/2}}$$

$$N_s = \frac{N Q^{1/4}}{H_m^{3/4}} \quad (6)$$

MULTI-STAGE CENTRIFUGAL PUMPS:

If centrifugal pump consists of two or more impellers, the pump is called a multi-stage centrifugal pump. The impeller may be mounted on the same shaft or on different shafts. A multi-stage pump is having the following two important functions:

- 1) To produce a high head and
- 2) To discharge a large quantity of liquid.

If a high head is to be developed, the impellers are connected in series (or on the same shaft) while for discharging large quantity of liquid, the impellers (or pumps) are connected in parallel.

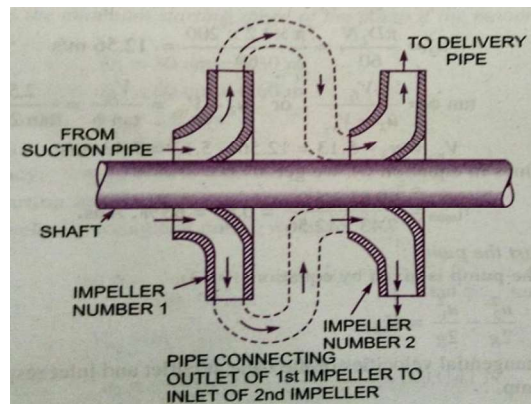

Multi-Stage Centrifugal Pumps for High Heads: For developing a high head, a number of impellers are mounted in series on the same shaft.

The water from suction pipe enters the 1st impeller at inlet and is discharged at outlet with increased pressure. The water with increased pressure from the outlet of the 1st impeller is taken to the inlet of the 2nd impeller with the help of a connecting pipe. At the outlet of the 2nd impeller the pressure of the water will be more than the water at the outlet of the 1st impeller. Thus if more impellers are mounted on the same shaft, the pressure at the outlet will be increased further.

Let n = Number of identical impellers mounted on the same shaft,

H_m = Head developed by each impeller.

Then total Head developed = $n \times H_m$

The discharge passing through each impeller is same.

Multi-Stage Centrifugal Pumps for High Discharge:

For obtaining high discharge, the pumps should be connected in parallel. Each of the pumps lifts the water from a common sump and discharges water to a common pipe to which the delivery pipes of each pump is connected. Each of the pumps is working against the same head.

Let n = Number of identical pumps
arranged in parallel.

Q = Discharge from one pump.

\therefore Total Discharge = $n \times Q$

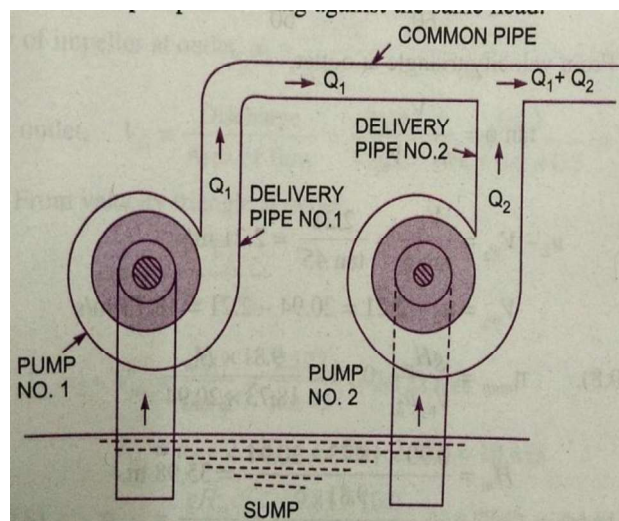

Performance Characteristic Curves of centrifugal pumps

The characteristic curves of a centrifugal pump are defined as those curves which are plotted from the results of a number of tests on the centrifugal pump. These curves are necessary to predict the behavior and performance of the pump, when the pump is working under different flow rate, head and speed. The following are the important characteristic curves for the pumps:

1. Main characteristic curves.
2. Operating characteristic curves and
3. Constant efficiency or Muschel curves.

1. Main Characteristic Curves: the main characteristic curves of a centrifugal pump consists of a head (Manometric head H) power and discharge with respect to speed. For plotting curves of Manometric head versus speed, discharge is kept constant. For plotting curves of discharge versus speed, Manometric head (H) is kept constant. For plotting curves power versus speed, Manometric head and discharge are kept constant.

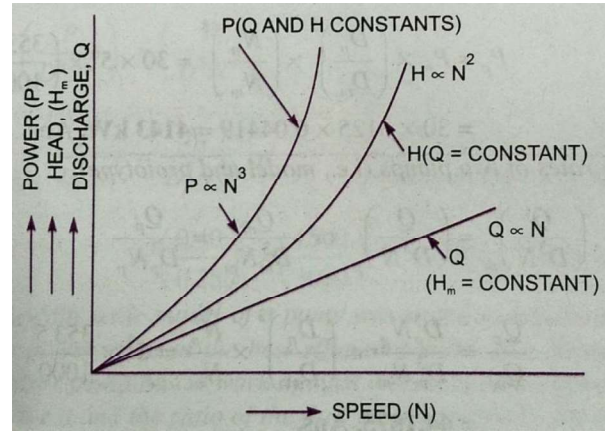

For plotting the curve of H_m versus speed (N) the discharge is kept constant. From the equation it is clear that $\frac{H_m}{DN}$ is a constant or $H_m \propto N^2$. This means that the head developed by a pump is proportional to N^2 . Hence the curve of H_m v/s N is a parabolic curve.

From equation $\frac{P}{D^5 N^3}$ is a constant. Hence $P \propto N^3$. This means that the curve P v/s N is a cubic curve.

The equation $\frac{Q}{D^3 N} = \text{constant}$. This means $Q \propto N$ for a given pump. Hence the curve Q v/s N is straight line.

2 Operating Characteristic Curves:

If the speed is kept constant, the variation of Manometric head, power and efficiency with respect to discharge gives the operating characteristics of the pump.

The input power curve for pumps shall not pass through the origin. It will be slightly away from the origin on the y-axis, as even at zero discharge some power is needed to

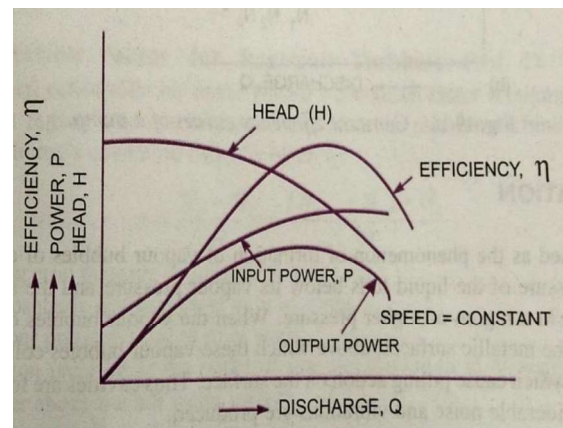

overcome mechanical losses.

The head curve will have maximum value of head when the discharge is zero.

The output power curve will start from origin as at $Q=0$, output power ρQgH will be zero.

The efficiency curve will start from origin as at $Q=0$, $\eta = 0$. $\therefore \eta = \frac{\text{Output}}{\text{Input}}$

3. Constant Efficiency Curves:

For obtaining constant efficiency curves for a pump, the head versus discharge curves and efficiency v/s discharge curves for different speeds are used. By combining these curves

$\eta \sim Q$ curves $\eta \sim Q$ curves constant efficiency curves are obtained.

For plotting the constant efficiency curves (Iso-efficiency curves), horizontal lines representing constant efficiencies are drawn on the $\eta \sim Q$ curves. The points, at which these lines cut the efficiency curves at various speeds, are transferred to the corresponding $H \sim Q$ curves. The points having the same efficiency are then joined by smooth curves. These smooth curves represent the iso-efficiency curves.

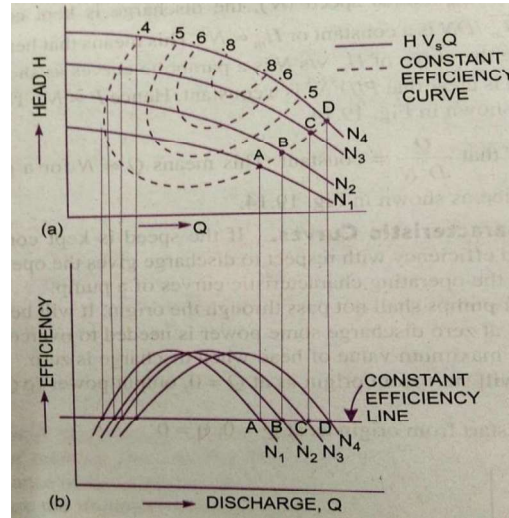

NET POSITIVE SUCTION HEAD (NPSH)

The term NPSH is very commonly used selection of a pump. The minimum suction conditions are specified in terms NPSH.

It is defined as the absolute pressure head at the inlet to the pump minus the vapour pressure head plus velocity head.

\therefore NPSH = Absolute pressure head at inlet of pump – vapour pressure head (absolute units)

$$= \frac{p_1}{\rho g} - \frac{p_v}{\rho g} + \frac{v_s^2}{2g} \quad (1) \quad \text{Absolute pressure at inlet of pump} = p_1$$

The absolute pressure head at inlet of the pump is given by as

$$\frac{p_1}{\rho g} = \frac{p_a}{\rho g} - \frac{v_s^2}{2g} + \sum s + \sum f_s$$

Substituting this value in the above equation

$$NPSH = \frac{p_a}{\rho g} - \frac{v_s^2}{2g} - \sum s - \sum f_s - \frac{p_v}{\rho g} + \frac{v_s^2}{2g}$$

$$\begin{aligned}
&= \frac{p_a}{\rho g} - \frac{p_v}{\rho g} - \frac{v_s^2}{2g} - \frac{v_f^2}{2g} \\
&= H_a - H_v = H_s + H_f \qquad \therefore \frac{p_a}{\rho g} = H_a = \text{Atmospheric pressure head,} \\
&= H_a - \frac{v_s^2}{2g} - \frac{v_f^2}{2g} - H_v \qquad \therefore \frac{p_v}{\rho g} = H_v = \text{Vapour head}
\end{aligned}
\tag{2}$$

The right hand side of the above equation is the total suction head. Hence NPSH is equal to the total suction head. Thus NPSH may also be defined as the total head required to make the liquid flow through the suction pipe to the pump impeller.

For any pump installation, a distinction is made between the required NPSH and the available NPSH. The value of required NPSH is given by the pump manufacturer. This value can also be determined experimentally. For determining its value the pump is tested and minimum value of v_s is obtained at which the pump gives maximum efficiency without any noise. (i.e. cavitation free). The required NPSH varies with the pump design, speed of the pump and capacity of the pump.

When the pump is installed, the available NPSH is calculated from the above equation (2). In order to have cavitation free operation of centrifugal pump, the available NPSH should be greater than the required NPSH.

RECIPROCATING PUMPS

The mechanical energy is converted into hydraulic energy (pressure energy) by sucking the liquid in to a cylinder in which a piston is reciprocating, which exerts the thrust on the liquid and increases its hydraulic energy (pressure energy) the pump is known as reciprocating pump.

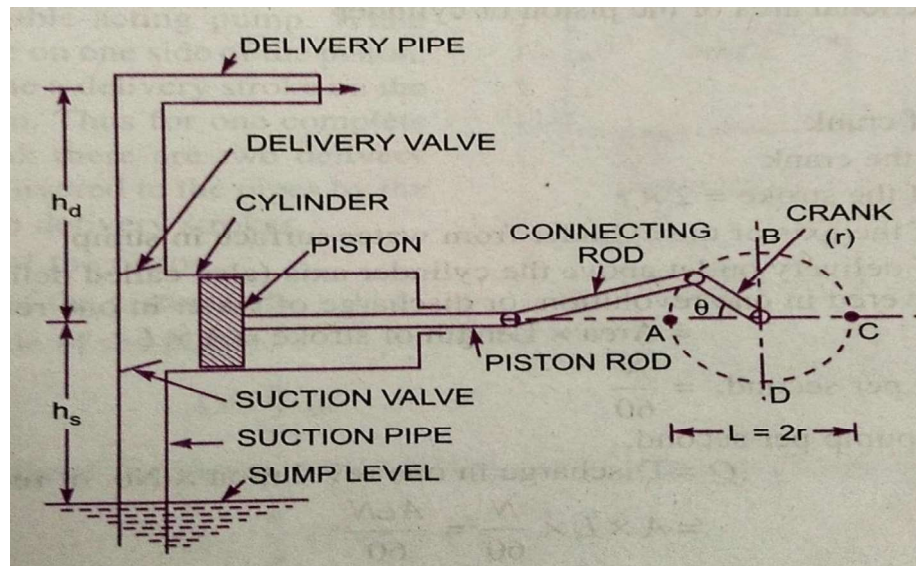

A single acting reciprocating pump consists of a piston, which moves forwards and backwards in a close fitting cylinder. The movement of the piston is obtained by connecting the piston rod to crank by means of a connecting rod. The crank is rotated by means of an electric motor. Suction and delivery pipes with suction valve and delivery valve are connected to the cylinder. The suction and delivery valves are one way valves or non-return valves, which allow the water to flow in one direction only. Suction valve allows water from suction pipe to the cylinder which delivery valve allows water from cylinder to delivery pipe only.

When the crank starts rotating, the piston moves to and fro in the cylinder. When the crank is at A the piston is at the extreme left position in the cylinder. As the crank is rotating from A to C (i.e. from $\theta = 0$ to 180°) the piston is moving towards right in the cylinder. The movement of the piston towards right creates a partial vacuum in the cylinder. But on the surface of the liquid in the sump atmospheric pressure is acting, which is more than the pressure inside the cylinder. Thus the liquid is forced in the suction pipe from the sump. This liquid opens the suction valve and enters the cylinder.

When crank is rotating from C to A (i.e. from $\theta = 180^\circ$ to 360°), the piston from its extreme right position starts moving towards left in the cylinder. The movement of the piston towards the left increases the pressure on the liquid inside the cylinder more than atmospheric pressure. Hence the suction valve closes and delivery valve opens. The liquid is forced in to the delivery pipe and is raised to the required height.

Discharge through a Reciprocating Pump:

Consider a single acting reciprocating pump.

Let D = Diameter of cylinder

$$A = \text{Cross-sectional area of piston or cylinder} = \frac{\pi}{4} D^2$$

r = Radius of crank

N = r.p.m. of the crank

L = Length of the stroke = $2 \times r$

h_s = Height of the axis of the cylinder from water surface in sump

h_d = Height of delivery outlet above the cylinder axis (also called delivery

head) Volume of water delivered in one revolution or

Discharge of water in one revolution = Area \times Length of stroke

$$= A \times L$$

Number of revolutions per second = $\frac{N}{60}$

Discharge of pump per second Q = Discharge in one revolution \times No. of revolutions per sec

$$= A \times L \times \frac{N}{60}$$

$$= \frac{ALN}{60}$$

Weight of water delivered per second $W = \rho \times g \times Q$

$$= \frac{\rho g A L N}{60} \quad \text{_____ (1)}$$

Work done by Reciprocating Pump:

Work done per second = Weight of water lifted per second \times Total height through which water is lifted

$$= \times [?]_s + [?]_d \quad \text{_____ (2)}$$

Where ${}_s + [?]_d$ = Total height through which water is lifted

From equation (1) weight of water is given by

$$W = \frac{\rho g A L N}{60}$$

Substituting the value of W in equation (2), we get

Work done per second $= \frac{\rho g A L N}{60} \times [?]_s + [?]_d$

Power required to drive the pump in kW

$$P = \frac{\text{Work done per second}}{1000} = \frac{\rho g \times A L N \times [?]_s + [?]_d}{60 \times 1000}$$

$$P = \frac{\rho g \times A L N \times [?]_s + [?]_d}{60,000} \text{ kW}$$

SLIP OF RECIPROCATING PUMP

Slip of a pump is defined as the difference between the theoretical discharge and actual discharge of a pump. The actual discharge of pump is less than the theoretical discharge due to leakage. The difference of the theoretical discharge and actual discharge is known as slip of the pump.

Hence $slip = Q_{t[?]} - Q_{act}$

But slip is mostly expressed as percentage slip

$$\text{Percentage slip} = \frac{Q_{t[?]} - Q_{act}}{Q_{t[?]}} \times 100 = 1 - \frac{Q_{act}}{Q_{t[?]}} \times 100$$

$$= 1 - C_d \times 100 \quad \therefore \frac{Q_{act}}{Q_{t[?]}} = C_d$$

Where C_d = Co-efficient of discharge.

Negative Slip of the Reciprocating Pump:

Slip is equal to the difference of theoretical discharge and actual discharge. If actual discharge is more than the theoretical discharge, the slip of the pump will become -ve. In that case the slip of the pump is known as negative slip.

Negative slip occurs when the delivery pipe is short, suction pipe is long and pump is running at high speed.

INDICATOR DIAGRAM

The indicator diagram for a reciprocating pump is defined the graph between the pressure head in the cylinder and the distance travelled by piston from inner dead centre for one complete revolution of the crank. As the maximum distance travelled by the piston is equal to the stroke length and hence the indicator diagram is a graph between pressure head and stroke length of the piston for one complete revolution. The pressure head is taken as ordinate and stroke length as abscissa.

Ideal Indicator Diagram:

The graph between pressure head in the cylinder and the stroke length of piston for one complete revolution of the crank under ideal conditions is known as ideal indicator diagram. Line EF represents the atmospheric pressure head equal to 10.3 meters of water.

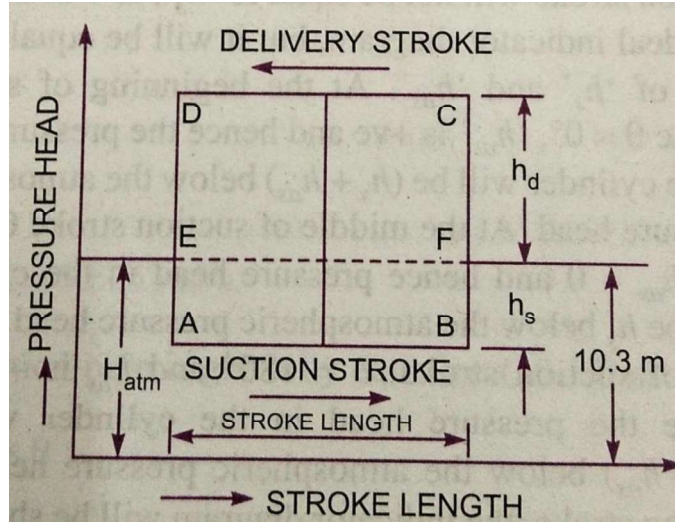

Let $H =$ Atmospheric pressure head = 10.3 m of water

$L =$ Length of the stroke

$h_s =$ Suction head and

$h_d =$ Delivery head

During suction stroke, the pressure head in the cylinder is constant and equal to suction head h_s , which is below the atmospheric pressure head H_{atm} by a height of h_s . The pressure head during suction stroke is represented by a horizontal line AB which is below the line EF by a height of h_s

During delivery stroke, the pressure head in the cylinder is constant and equal to delivery head (h_d), which is above the atmospheric head by a height of h_d . Thus the pressure head during the delivery stroke is represented by a horizontal line CD, which is above the line EF by a height of h_d . Thus for one complete revolution of crank, the pressure head in the cylinder is represented by the diagram ABCD. This diagram is known as ideal indicator diagram.

$$\begin{aligned} \text{The work done by the pump per second} &= \frac{\rho g A L N}{60} \times h_s + h_d \\ &= K \times L (h_s + h_d) \\ &\propto L \times (h_s + h_d) \quad \text{---(1)} \end{aligned}$$

Where $K = \frac{\rho g A N}{60} = \text{constant}$

$$\text{Area of Indicator diagram} = AB \times BC = AB \times (h_s + h_d) = L \times (h_s + h_d)$$

Substituting this value in equation (1), we get

Work done by pump \propto Area of Indicator diagram

Problems on reciprocating pump.

1. A single acting reciprocating pump running at 50 r.p.m. delivers $0.01 \text{ m}^3/\text{s}$ of water. The diameter of piston is 200mm and stroke length in 400mm. Determine

i) The theoretical discharge of pump ii) Co-efficient of discharge

iii) Slip and the percentage slip of pump

Given: The speed of the pump $N = 50 \text{ rpm}$

$$\text{Actual discharge } Q_{act} = 0.01 \text{ m}^3/\text{s}$$

$$\text{Dia. Of piston } D = 200\text{mm} = 0.2\text{m}$$

$$\text{Area } A = \frac{\pi D^2}{4} = \frac{\pi 0.2^2}{4} = 0.031416 \text{ m}^2$$

$$\begin{aligned} \text{i) The theoretical discharge } Q_{t \text{ [2]}} &= \frac{ALN}{60} = \frac{0.031416 \times 0.4 \times 50}{60} \\ &= \mathbf{0.01047 \text{ m}^3/\text{s}} \end{aligned}$$

$$\begin{aligned} \text{ii) The Co-efficient of discharge } C_d &= \frac{Q_{at}}{Q_t} = \frac{0.01}{0.01047} \\ &= \mathbf{0.955} \end{aligned}$$

$$\begin{aligned} \text{iii) Slip } Q_{t \text{ [2]}} - Q_{act} &= 0.01047 - 0.01 \\ &= \mathbf{0.00047 \text{ m}^3/\text{s}} \end{aligned}$$

$$\begin{aligned} \text{Percentage Slip} &= \frac{Q_{t \text{ [2]}} - Q_{act}}{Q_{t \text{ [2]}}} \times 100 \\ &= \frac{0.01047 - 0.01}{0.01047} \times 100 \\ &= \mathbf{4.489\%} \end{aligned}$$

2. A double acting reciprocating pump, running at 40 r.p.m. is discharging 1.0m³ of water per minute. The pump has a stroke of 400 mm. the diameter of piston is 200 mm. the delivery and suction head are 20m and 5m respectively. Find the slip of the pump and power required to drive the pump.

Given: Speed of the pump $N = 40$ r.p.m.

$$\text{Actual discharge } Q_{act} = 1 \text{ m}^3/\text{s} = \frac{1}{60} = 0.01666\text{m}^3/\text{s}$$

$$\text{Stroke } L = 400\text{mm} = 0.4\text{m}$$

$$\text{Diameter of piston } D = 200 \text{ mm} = 0.2\text{m}$$

$$\therefore \text{Area } A = \frac{\pi D^2}{4} = \frac{\pi 0.2^2}{4} = 0.031416\text{m}^2$$

$$\text{Suction Head } H_s = 5\text{m}$$

$$\text{Delivery head } H_d = 20 \text{ m}$$

Theoretical discharge for double acting pump

$$Q_t = \frac{2ALN}{60} = \frac{2 \times 0.31416 \times 0.4 \times 40}{60} \\ = 0.01675\text{m}^3/\text{s}$$

$$\text{Slip } Q_t - Q_{act} = 0.01675 - 0.01666 \\ = 0.00009\text{m}^3/\text{s}$$

Power required to drive the double acting pump

$$P = \frac{2 \times \rho g \times ALN \times (H_s + H_d)}{60,000} \\ = \frac{2 \times 1000 \times 9.81 \times 0.031416 \times 0.4 \times 40 \times 5 + 20}{60,000} \\ = 4.109\text{kW}$$